



OIL-FIRED CENTRAL FURNACE

Installation, Operation, and Service Manual

With Users Information Section

Models:

OD6FA072D48(B/R/C)

OD6RA072D48(B/R/C)

OD6FA072DV5(B/R/C)

OD6RA072DV5(B/R/C)

⚠ WARNING: IF THE INFORMATION IN THESE INSTRUCTIONS IS NOT FOLLOWED EXACTLY, A FIRE OR EXPLOSION MAY RESULT CAUSING PROPERTY DAMAGE, PERSONAL INJURY, OR LOSS OF LIFE.

DO NOT STORE OR USE GASOLINE OR OTHER FLAMMABLE VAPORS AND LIQUIDS IN THE VICINITY OF THIS OR ANY OTHER APPLIANCE.

⚠ WARNING: IMPROPER INSTALLATION, ADJUSTMENT, ALTERATION, SERVICE, OR MAINTENANCE CAN CAUSE INJURY OR PROPERTY DAMAGE. REFER TO THIS MANUAL. FOR ASSISTANCE OR ADDITIONAL INFORMATION CONSULT A QUALIFIED INSTALLER, OR SERVICE AGENCY.

⚠ AVERTISSEMENT: SI L'INFORMATION DANS CES INSTRUCTIONS N'EST PAS SUIVI À LA LETTRE, UN INCENDIE OU UNE EXPLOSION ENTRAÎNANT DES DOMMAGES MATÉRIELS, DES BLESSURES CORPORELLES OU DES PERTES DE VIE.

NE PAS ENTREPOSER NI UTILISER D'ESSENCE OU AUTRES VAPEURS ET LIQUIDES INFLAMMABLES À PROXIMITÉ DE CET APPAREIL OU DE TOUT AUTRE APPAREIL.

⚠ AVERTISSEMENT: UNE MAUVAISE INSTALLATION, D'AJUSTEMENT, DE LA MODIFICATION, D'ENTRETIEN OU DE MAINTENANCE PEUVENT CAUSER DES BLESSURES OU DOMMAGES MATÉRIELS, REPORTEZ-VOUS À CE MANUEL POUR OBTENIR DE L'AIDE OU DES RENSEIGNEMENTS SUPPLÉMENTAIRES, CONSULTER UN INSTALLATEUR QUALIFIÉ, OU ORGANISME DE SERVICE.

PLEASE READ THESE INSTRUCTIONS PRIOR TO INSTALLATION, INITIAL FIRING, AND BEFORE PERFORMING ANY SERVICE OR MAINTENANCE. THESE INSTRUCTIONS MUST BE LEFT WITH THE USER AND SHOULD BE RETAINED FOR FUTURE REFERENCE BY QUALIFIED SERVICE PERSONNEL.

VEUILLEZ LIRE CES INSTRUCTIONS AVANT L'INSTALLATION, LES PREMIERS TIRS, ET AVANT D'EFFECTUER TOUT ENTRETIEN OU MAINTENANCE. CES INSTRUCTIONS DOIVENT ÊTRE LAISSÉS AVEC L'UTILISATEUR ET DEVRAIT ÊTRE CONSERVÉ POUR RÉFÉRENCE FUTURE PAR UN TECHNICIEN QUALIFIÉ.

Manufactured by:
THERMO PRODUCTS, LLC.
PO BOX 237
DENTON, NC 27239



MO-545
ECN 5762-MA 230124

Made in USA

Contents

SECTION	PAGE
Notice to the Installer	3
INSTALLATION GUIDELINES	5
Codes	5
Installation Location	5
Closet and Alcove Installation	6
Standard Clearances	6
Air for Combustion and Ventilation	7
Chimney Inspection	9
Flue / Chimney / Vent Connector	10
Blocked Vent Switch	10
Draft Regulator	10
Direct Venting	11
Power (Side-Wall) Venting – Important Note Regarding	11
Duct Work and Air Conditioning	12
Air Filter Mounting	12
Electrical Connections	13
Room Thermostat	13
Combustion Chamber	14
Oil Burner and Oil Nozzle Installation	14
Fuel System Installation	16
INITIAL OPERATION OF THE FURNACE	16
Initial Burner Operation	16
Supply/Return Airflow and Air Temperature	17
Furnace Limit and Blower Controls	18
Operational Modes	19
Instructions to Our Customer / End User	21
SERVICE	21
Control Diagnostics	21
Troubleshooting	22
Flame Sensor (“Cad Cell”) Checkout Procedure	24
Replacement Parts	24
MAINTENANCE	24
Air Filter(s)	24
Oil Burner	24
Blower and Motor	25
Heat Exchanger	25
Flue and Chimney	26
USERS INFORMATION	27

Operating Instructions	27
Oil Supply	28
Extended Shutdown	28
Combustion Air and Ventilation Supply	29
Inspection Areas	29
APPENDIX A: START-UP DATA SHEET	30
APPENDIX B: ELECTRICAL DIAGRAMS	31
APPENDIX C: SPECIFICATION SHEETS	35
APPENDIX D: REPLACEMENT PARTS	36
WARRANTY	43

Notice to the Installer

Installation of this oil-fired furnace **must** be performed by a qualified installer in accordance with all local codes and authorities having jurisdiction. In the absence of local governing codes, installation shall conform to these instructions and to the regulations of the National Fire Protection Association's Standard for the Installation of Oil-Burning Equipment, NFPA 31-2020, and the National Electrical Code, ANSI/NFPA 70-2017, or the latest editions thereof.

A qualified installer, also referred to in this instruction manual as a “qualified heating contractor”, **is an individual, or agency, properly licensed and experienced to install and service oil-burning equipment in accordance with all local codes and ordinances.**

Material and Workmanship

This furnace was built with the highest quality materials and attention to workmanship. However, omissions and defects occasionally occur. Before installing the furnace, inspect the furnace thoroughly. If missing parts, defective material, or poor workmanship is evident, report the **model** and **serial numbers** imprinted on the furnace rating label to the seller for adjustment.

Packaging

A complete furnace is contained within a single package. The factory completed all feasible assembly. However certain components including draft regulator and, if supplied, door handle, air filter(s), and air filter rack(s), must be assembled to the furnace, or the venting system, in the field. Refer to the assembly instructions.

Shipping Damage

If this furnace was damaged during transit, please immediately request the transportation company inspect the furnace and issue a **concealed damage report**. The party receiving the furnace should file the claim for shipping damage. **Report any shipping damage immediately.**

It is absolutely essential that a damage report be obtained. If a concealed damage report is not obtained, we cannot provide assistance in recovering your claim against the transportation company.

Warranties

⚠ WARNING: The manufacturer of this equipment assumes no liability for any damages resulting from unauthorized modifications made to the furnace, or any components thereof, or improper installation of the furnace

in the field. Furthermore, any such field modifications VOID THE WARRANTY and place responsibility for safe and reliable operation of the furnace on those who performed the modification(s).

Complete and return any enclosed warranty cards. These must be on file to verify installation dates for replacement of any warranted part(s).

INSTALLATION GUIDELINES

Codes

All local codes and regulations take precedence over the instructions in this manual and shall be followed accordingly. In the absence of local codes, this installation must conform to these instructions and to the regulations of the National Fire Protection Association (NFPA) publications, the Standard for the Installation of Oil-Burning Equipment, NFPA 31-2020, and the National Electrical Code, ANSI/NFPA 70-2017 or the latest editions thereof,

Installation Location

⚠ WARNING:

- **These furnaces are designed for indoor installation ONLY.**
- **These furnaces are NOT to be used as construction heaters.**
- **DO NOT hang the horizontal / counterflow furnace from a structure, or surface, by any integral part or fastener of the furnace. The furnace was not designed to support itself in this manner.**

In as much as practical, the furnace should be positioned near a chimney or vent and should be centralized with respect to the air distribution system.

For a utility room installation, the entrance door must be wide enough to permit the largest part of the furnace to pass through the doorway or allow sufficient clearance to permit the replacement of another appliance, e.g. a water heater, in the room.

If the furnace is installed in a residential garage, it must be installed so the burner is located higher than 18 inches above the floor, unless the required combustion air is taken from the exterior of the garage. Also, the furnace must be located or protected to avoid physical damage from impacts by vehicles.

It is recommended that a commercially available CO alarm be installed in conjunction with any fossil fuel burning appliance. The CO alarm shall be installed according to the alarm manufacturer's installation instructions and be listed in accordance with the latest edition of the UL Standard for Single and Multiple Station Carbon Monoxide Alarms, UL 2034, or the CSA International Standard, Residential Carbon Monoxide Alarming Devices, CSA 6.19.

The furnace shall not be operated in a condition where the return air is consistently below 55°F.

Closet and Alcove Installation

All furnace models covered in this manual may be installed in a closet or alcove with specified (standard) clearances to combustible construction. When installed in a counterflow configuration a combustible surface-mounting base (Model # D6-BASE) must be used for when installing on combustible materials, refer to Figure 1.

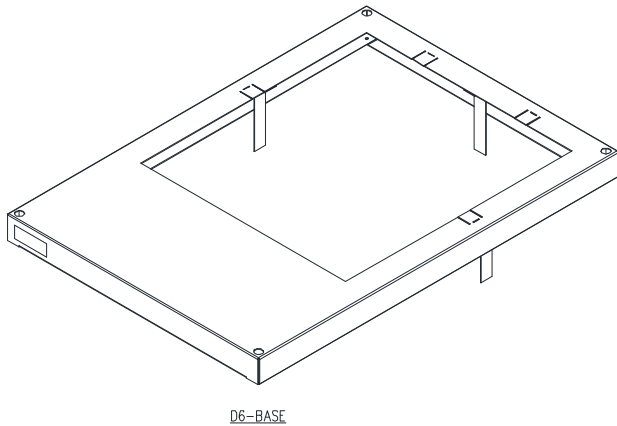

Figure 1: Counterflow Furnace Combustible Surface-Mounting Base

Standard Clearances

Standard clearances are mandatory minimum clearances from heated surfaces of the furnace to combustible materials to assure protection from fire hazard during furnace operation. (Refer to the Standard for the Installation of Oil-Burning Equipment, NFPA 31-2020, or latest edition, for definitions of combustible and non-combustible materials.

Accessibility clearances, which are typically greater, may exceed fire protection clearances. Therefore, consider providing at least 24 inches of clearance from the front of the furnace to obstructions and surfaces for adequate service and maintenance access.

The minimum clearances from furnace casing surfaces to combustible materials are:

- 0 inches from casing sides and rear
- 6 inches from front casing of furnace
- 7 inches from flue pipe/vent connector
- 1 inches from casing top
- 1 inches from any side of supply air plenum
- 1 inches above supply air ducts, within 6 feet of furnace

Air for Combustion and Ventilation

⚠ CAUTION: Relief openings in the front or top of the furnace casing should not be obstructed or blocked. These openings supply combustion and ventilation air to the furnace.

Chloride, fluoride, iodide, and bromide bearing compounds when present, even in low concentrations, are in air supplied for combustion to the furnace, can result in accelerated and severe corrosion of the heat exchanger and/or the venting system.

Often, household chemicals contain chloride-bearing compounds. There are many compounds representative of this classification of chemicals. A few common examples are listed below.

- Cleaning solvents
- Varnish and paint removers
- Bleaches
- Fabric softeners
- Water softener salt
- Tile adhesives

Avoid storing or using these chemicals within close proximity to the furnace. In addition, avoid storing or using any chemicals, of an unknown and possibly flammable nature, in close proximity to the furnace.

The furnace shall be installed in a location within the building that permits a satisfactory supply of air for combustion, ventilation, and proper operation of the venting system. While all forms of building construction cannot be covered in detail in this manual, this requirement may usually be met by application of one of the following methods in ordinary building construction. However, applicable local installation codes **always** take precedence and shall be followed.

The content of certain pertinent passages of NFPA on methods to obtain and ensure adequate airflow to the furnace has been excerpted and, in some cases, paraphrased below for reference purposes. Consult the Standard for the Installation of Oil-Burning Equipment, NFPA 31-2020, or latest addition for special cases and further details.

1. Utility Room (example of a confined space)
 - a. In buildings of conventional construction with normal air infiltration, two (2) permanent openings connecting to a well-ventilated crawl space, attic, or another large, well-ventilated internal area shall be provided. Each opening shall have a minimum free area of one (1) square inch per 1000 BTUH of total input rate (sum of the individual appliance input rates) of all appliances to be installed in the utility room. One opening

should be located near, or in, the ceiling of the room and the other should be located near, or in, the floor.

- b. In buildings of unusually tight construction (those having 0.35 air changes per hour, or less); provision must be made to provide sufficient air for combustion. The following method will usually be adequate to ensure sufficient airflow into the space.

Provide two (2) permanent openings, one (1) located within 12 inches of the floor and one (1) within 12 inches of the ceiling, or roof, of the room. These openings shall allow for direct exchange of air between the room and outdoors. If required, ducting between the room and the outdoors shall be provided.

- For horizontally -oriented ducts, each opening shall have a minimum free area of one (1) square inch per 2000 BTUH of the total input rate (sum of the individual appliance input rates) of all appliances to be installed in the room.
- For vertically -oriented ducts, the minimum free area may be reduced to one (1) square inch per 4000 BTUH of the total input rate (sum of the individual appliance input rates) of all appliances to be installed in the room.
- The minimum dimension of any air opening shall not be less than 3-inches.
- When an opening in the outside wall must be provided, it should be furnished with properly screened metal sleeves.

2. Full Basement (example of an unconfined space)

- a. Where a furnace is installed in a full basement, in a building of conventional construction with normal air infiltration, infiltration is normally adequate to provide air for combustion and ventilation.
- b. In buildings of unusually tight construction (such as those where weather stripping and storm sash windows are used, and where basement windows are also weather-stripped), one (1) permanent opening connecting to a well-ventilated attic, or with the outdoors shall be provided, using a duct, if necessary. This opening shall have a minimum free area of one (1) square inch per 5000 BTUH of total input rate (sum of the individual appliance input rates) of all appliances to be installed in the basement.

When an opening in the outside wall must be provided, it should be furnished with properly screened metal sleeves.

If an exhaust fan or additional air consuming machines (e.g. a cloth dryer), is present in the furnace room, there should be increased concern about providing adequate airflow to the furnace. Additional efforts may be required to assure an adequate supply of combustion and ventilation air is available to the furnace under all conditions.

When needed it is possible to have combustion air connected directly to the burner of these furnaces to the outdoors by using appropriate Combustion Air Kit listed below.

COMBUSTION AIR INTAKE HOOD KIT ORDER INFORMATION	
BURNER	THERMO PRODUCTS PART NUMBER
Beckett AFG	AOPS8397
Riello BF3	AOPS8416
Carlin EZ-1HP	AOPS8433

Table 1: Combustion air intake hood kits

Chimney Inspection

The chimney, vent, or any passageway for the stack gases to flow to the outdoor atmosphere is a very important part of the heating system. No furnace, regardless of the efficiency of the design, can perform satisfactorily when the chimney to which it is connected is inadequate or in poor condition. Any of the following symptoms may indicate a chimney has severe structural damage and is unsuitable for use.

- Chimney appears to be leaning to the side.
- Chimney appears to have structural damage, i.e. loose or missing blocks or bricks, or excessive deterioration at mortar joints.
- Tile liner damaged or missing.
- Flue gas leakage along the length of the chimney between the chimney connector and discharge termination.
- Excessive corrosion at the cleanout port or at the chimney connector entrance into the chimney.
- Structural debris, i.e. mortar or tile liner flakes, in base of the flue way.

A qualified person shall inspect the chimney to confirm it is correctly sized for the application, properly constructed, and in sound condition. Refer to the Standard for the Installation of Oil-Burning Equipment, NFPA 31-2001, for details on proper chimney sizing and construction. If needed, the chimney should be cleaned before installing the furnace. Any accumulation of dirt or debris at the bottom of the flue should be removed.

Flue / Chimney / Vent Connector

⚠ CAUTION:

- **DO NOT install a manual damper in the chimney or vent connector.**
- **Thermally- activated type vent dampers are NOT recommended for use on these furnaces.**

It is desirable to install the shortest vent connector (also referred to as a flue or chimney connector) possible with the fewest number of fittings, i.e. transitions and elbows. Generally, 6-inch diameter, 24 Ga. or heavier, single wall, lock seam-type, galvanized steel vent pipe and fittings are satisfactory materials for the fabrication of a vent connector. However, always consult local codes and authorities for specific minimum requirements.

On a front flue unit the flue can exit through the top, left or right side casing, or through the front door. Remove the appropriate knock-out in the casing panel for the chosen venting location.

All horizontal sections of the vent connector must slope upward not less than $\frac{1}{4}$ inch per foot from the furnace to the vent termination. Long horizontal sections of the venting system must be supported at least every five (5) feet with metal straps to prevent sagging of the vent piping. Secure all joints in the vent connector with sheet metal screws or equivalent fasteners. Vent piping must **not** be inserted beyond the inside wall of the chimney flue.

Blocked Vent Switch

The blocked vent switch kit must be installed to comply with CAN STD B140.4 where applicable. Installation instructions are provided with the Blocked Vent kit, part no. AOPS2686

Draft Regulator

A barometric-type, draft regulator is supplied with the furnace. Installation or operating conditions that produce excess amounts of draft can reduce the heating efficiency of the furnace. The purpose of the regulator is to adjust and control the flow of flue gases from the furnace by stabilizing the amount of chimney draft to which the furnace is subjected.

Always refer to the draft regulator manufacturer's installation instructions for application specific recommendations.

Direct Venting

The OD6 may also be horizontally vented through a side wall. Direct venting is only allowed when using the approved Direct Vent Termination kit and Direct Vent Accessory kit listed in the table below, and is limited to a maximum length of 15’.

SIDE WALL VENTING APPLICATION ORDER INFORMATION		
BURNER	VENT TERMINATION KIT (15’ application MAX) PART NUMBER	SIDE WALL VENT ACCESSORIES KIT PART NUMBER
Beckett AFG	AOPS8393	AOPS8394
Riello BF3	AOPS8393	AOPS8395
Carlin EZ-1HP	AOPS8393	AOPS8432

Table 2: Side wall vent kits

The Direct Vent Termination kit consists of a concentric through-the-wall vent termination/inlet air vent hood and 15’ of Stainless Steel Insulated Flexible Pipe that requires 2” clearance to combustibles.

A field supplied smooth wall 4” combustion air pipe will need to be provide to connect the combustion air from the termination hood to the burner. The direct vent accessory kit will provide the fittings needed to connect the 4” pipe to the burner. The combustion air inlet can be installed through the either the lower left or right side casing knock-out.

For proper installation follow the Instruction provide with the Direct Vent Termination Kit.

Power (Side-Wall) Venting – Important Note Regarding

⚠ CAUTION: Thermo Products, LLC will NOT assume responsibility for damage to, and deterioration of, exterior building materials, e.g. brick, siding, clapboards, and etc., in close proximity to the vent terminal due to operation of a power vented, oil furnace. This policy is applicable regardless of the cause of sooting.

NOTICE: Thermo Products recommends the use of a chimney to vent residential oil furnaces. If a power venter must be used, it is the responsibility of the installer and power venter manufacturer to design, assemble, and demonstrate proper operation of the power venting system with the furnace.

Duct Work and Air Conditioning

Design and installation of the duct system should follow the current guidelines of the Air Conditioning Contractors of America (ACCA) or the American Society of Heating, Refrigeration and Air Conditioning Engineers, Inc. (ASHRAE). Refer to the Residential Duct Systems, Manual D, from the ACCA, and the ASHRAE Handbook Fundamentals volume, from ASHRAE, for recommended practices in duct system design and installation.

All furnaces are tested over a range of external static pressure that simulates the airflow resistance of the ductwork, fittings, and diffusers connected to the furnace for a typical (average) duct system. The furnace blower and blower motor have been selected to work successfully against the following range of duct system resistance.

Recommended range of the duct system external static pressure for all models: 0.2 to 0.5 in. W.G...

Due to the need to maintain an adequate supply of combustion and ventilation air, the furnace shall not be installed in small room without return air duct system. A return air duct shall be connected to the furnace return air opening and extend to a location outside the furnace room.

If the furnace is used in connection with a cooling coil, the coil must be installed in parallel with, or on the supply side of the furnace to avoid water vapor condensation in the furnace heat exchanger. If the cooling unit is installed in a parallel flow arrangement, dampers (or other means used to control airflow) should be provided to prevent chilled air from entering the furnace. If such a damper is manually operated, it must be equipped with a means to prevent operation of either unit, unless the damper is placed in either the full heat or full cool position.

NOTICE: Return air grilles and supply registers in the air distribution system should never be obstructed.

Air Filter Mounting

The OD6 comes with (2) two 19" x 13" reusable filters. A "W" style filter rack is shipped with the furnace for placement of the filters inside the return air plenum on counterflow installations. Access to the filters is through the removable blower door. For horizontal installations, it is recommended that return air grill filters be installed for homeowner access. See Fig. 2.

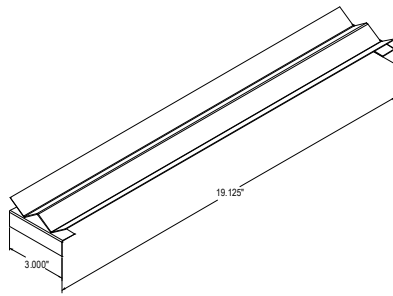

Fig. 2: Filter rack and dimensions for the OD6 furnace

Electrical Connections

NOTICE: All field wiring must conform to local, state, and national installation codes.

A disconnecting switch equipped with overcurrent protection rated at 15 A. (e.g. a time delay-type fuse or inverse time, circuit breaker) should be installed in the service line.

Since the furnace is entirely pre-wired at the factory, it is only necessary to connect the building electrical service lines to the two (2) pigtail wires extending from the junction box. The junction box is mounted inside the furnace burner compartment or mounted on the front exterior of the furnace, in the case of the horizontal / counterflow model. A ground connection must also be made in the junction box. The service lines to the furnace should be no smaller than 14 Ga., insulated copper wire with a temperature rating of 60°C, or greater.

Refer to the electrical diagrams contained in Appendix B of this manual for an electrical schematic, a connection diagram, and operating instructions.

Room Thermostat

A room thermostat must be connected to the Oil Furnace control. This is typically a low voltage (24 VAC) circuit. Consult the National Electrical Code, ANSI/NFPA 70-2017, or latest edition for guidelines for proper wiring methods and materials for this circuit. The room thermostat should be located on an interior wall in the natural circulating path of the room air.

The thermostat should **not** be installed in a location where it is directly exposed to,

- cold air infiltration, i.e. drafts from outside openings such as windows and doors,
- air currents produced by supply air registers, and
- heat from a nearby source, such as a fireplace, electrical appliances, lamps, solar radiation, a wall enclosing warm air ducts, a chimney, or a flue gas vent.

Most room thermostats are equipped with an adjustable heat anticipator, set the thermostat heat anticipator to match the control current of the furnace as indicated on the furnace wiring diagram.

Combustion Chamber

The furnace combustion chamber is a hollow, circular cylinder sealed at the bottom end and open at the top end. The chamber is made of a lightweight, insulating, “soft”, refractory material. The refractory material is composed of organically bound, alumina-silica fibers that protect the heat exchanger from the intense heat of the oil burner.

Oil Burner and Oil Nozzle Installation

⚠ CAUTION: This oil furnace is designed to use No. 2 or lighter distillate fuel (home heating) oil. A Bio-fuel mixture may be used but the mixture is not to exceed a B5.

This furnace is designed to utilize the following specially modified, oil burner:

- R.W. Beckett Corp. model AFG burner, specification # TP2501
- Riello model BF3, specification # C8511325
- Carlin model EZ-1HP, specification # 99032B

NOTICE: NO other burners may be used in this application.

The heat output from the furnace is fixed, based on the size of nozzle installed in the oil burner. Three (3) heat input rates are permissible: 70,000, 85,000, and 106,250 BTUH.

Nozzle selection (i.e. heating capacity of the furnace) shall be based on a rate of heat loss (heating load) calculation for the building. These calculations should be made according to the manuals provided by the Air Conditioning Contractors of America (ACCA) or the American Society of Heating, Refrigeration and Air Conditioning Engineers, Inc. (ASHRAE).

Refer to the Residential Load Calculation, Manual J, from the ACCA, and the ASHRAE Handbook Fundamentals volume, from ASHRAE, for the recommended procedure to compute the design heating load of a residence.

NOTICE: Remove all cardboard packing from around chamber before installing burner.

For horizontal installation rotate mounting plate and chamber retainer 90 degrees left or right, depending on furnace position. **DO NOT change the position of the chamber.** This unit is equipped with a chamber retainer. The retainer secures the

chamber during shipping and helps to maintain insertion depth. **DO NOT remove this retainer when installing burner.** (Refer to Fig.3).

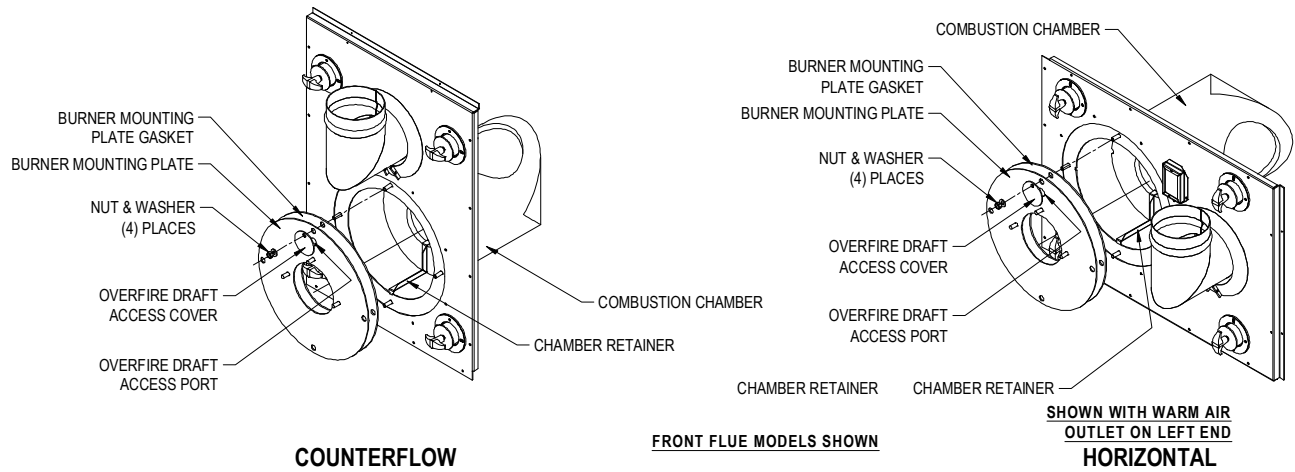

Fig. 3: Burner Mounting Plate for Counterflow and Horizontal Installations

When mounting the burner, (Fig 4) do not allow the burner tube or end cone to physically touch or protrude into the chamber, as excess heat transfer could result in destruction of the tube, end cone or both. The burner tube/end cone is properly positioned, when the end is 1/4 inch back from the inside surface of the combustion chamber wall. A fiber insulating sleeve is provided with the Riello BF3 Burner.

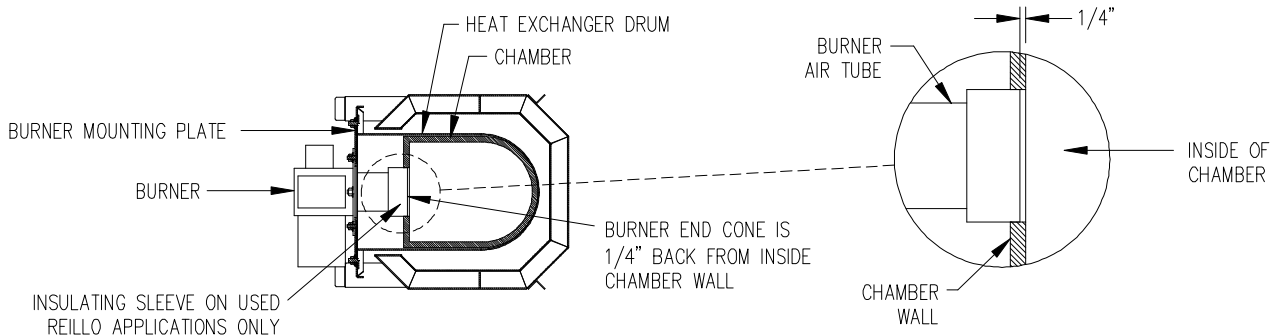

Fig. 4: Burner Insertion Illustration (Top view)

The oil burner provided with this furnace requires initial inspection, set-up, and proper adjustment. Refer to this manual and the oil burner manufacturer's operating instructions for detailed information on the following items.

- Initial firing of burner
- Adjusting the burner combustion air
- Adjusting the fuel pump pressure
- Setting the draft control

NOTICE: This oil furnace must be installed and adjusted by only qualified oil heating contractor using calibrated combustion test instruments to ensure safe and reliable operation of the furnace.

Fuel System Installation

In situations where the oil storage tank is installed at the same level with, or above, the burner, a single oil supply line run from the oil tank to the burner will be usually be adequate. No return line will be required. If the oil tank is installed below the burner and the lift exceeds approximately 6-ft., an oil supply line and an oil return line are recommended.

Refer to the Standard for the Installation of Oil-Burning Equipment, NFPA 31-2020, or latest edition and the oil burner operating instructions for detailed information on oil storage tank & oil supply/return line installation.

NOTICE: We recommend installing a high efficiency oil filter, in the oil supply line, capable of filtering 10 to 20 micron diameter (or preferably smaller) particles from the fuel.

Initial Operation of Furnace

Initial Burner Operation:

⚠ IMPORTANT: The start-up sheet found in Appendix A of this manual should be completed.

1. Turn the electrical disconnecting switch to the “OFF” position.
2. Set the room thermostat above room temperature.
3. Be sure the oil tank is full of clean # 2 fuel oil.
4. Open all shutoff valves in the oil line.
5. Refer to the oil burner manufacturer’s operating instructions (included with the furnace) for detailed startup instructions
6. Measure the oil pump pressure. If required, adjust it to deliver the appropriate pressure for the burner. The oil pump should be set to produce,
 - 120 PSIG, for the R.W. Beckett model AFG burner
 - 140 PSIG, for the Riello model BF3
 - 120 PSIG, for the Carlin model EZ-1HP
7. Carbon Dioxide (CO₂) and Carbon Monoxide (CO) – In order to assure that proper and safe combustion are taking place, carbon dioxide and carbon monoxide measurements must be taken. A CO₂ reading within

the limits of appendix C with no measurable CO is desirable. The maximum acceptable CO reading is about 50 PPM. If the CO reading is too high, open the burner air shutter, or air band, slightly to permit more combustion air to the flame. Recheck the CO level and adjust as required.

8. Draft – Draft measurements should be taken through the overfire port and in the vent connector, not more than 12 inches away from the furnace outlet. A 5/16 in. hex washer head bolt plugs the overfire port in the burner mounting plate. Remove the bolt and insert a suitable draft measurement gage.
9. Flue Gas Temperature – The flue gas temperature will vary depending on heat input rate, air temperature rise across the heat exchanger, and air flowrate through the furnace. To prevent excessive water vapor condensation from the flue gases, the gross flue gas temperature should not fall below 330°F. In addition, if the gross flue gas temperature exceeds 650°F, the heating efficiency of the furnace will be reduced.
10. Cycle the furnace several times to verify the burner lights off and shuts down smoothly without excessive noise or smoke production.

Supply/Return Airflow and Air Temperature (PSC)

The supply/return airflow shall be set to obtain an air temperature rise, across the furnace, in the range of 51° to 81°F. Since the flow resistance of each duct system is slightly different, the airflow (fan speed) may have to be changed in the field to achieve a satisfactory temperature rise.

The blower (fan) speed is adjusted by changing the fan motor winding energized by the control system. The furnace is set on the med-low fan speed, “ML”, at the factory; refer to furnace wiring diagram, Appendix B. To adjust the fan speed, follow this procedure.

- a. Turn off all electrical power to the furnace at the disconnecting switch.
- b. Remove the blower compartment access door on the counterflow/horizontal furnace.
- c. The “Heat” tab is the connection for the heating speed activation thru the fan board. If a change in heating speed is desired simply pull the wire from the heat tab and replace it with the desired motor speed wire. The Black (High) is connected to the “cool” tab for A/C speed operation. If a lower speed is desired for A/C, the speed is changed the same way. A tab marked “Low” is populated with a lower fan speed for continuous fan operation thru the “G” circuit of your T-stat. Unused blower speeds are connected to the “unused motor leads” tabs at bottom right of fan board.
- d. Replace the blower compartment access door on the counterflow/horizontal unit.
- e. Restore electrical power to the furnace at the disconnecting switch.

f. Recheck Temperature rise and adjust if needed.

Note: For furnace models with an ECM Blower Motor Refer to ECM Operation Manual provided with those furnaces for ECM blower speed adjustments.

Furnace Limit and Blower Controls

! WARNING: The predetermined fan and limit locations on all of the Thermo Pride oil fired furnaces have been tested and approved by Thermo Products, LLC. Any attempt to relocate these safety controls or replace these safety controls with a control that is not approved, or is incompatible, may result in personal injury, substantial property damage or death.

Thermo Pride oil furnaces can be equipped with one of the following two boards. Please refer to Fig. 5 to see which board you have.

Wiring Diagrams and Fan Speed Selection Charts can be found in this manual under Appendix B .

Refer to the Service section for operational and diagnostic feature of each board.

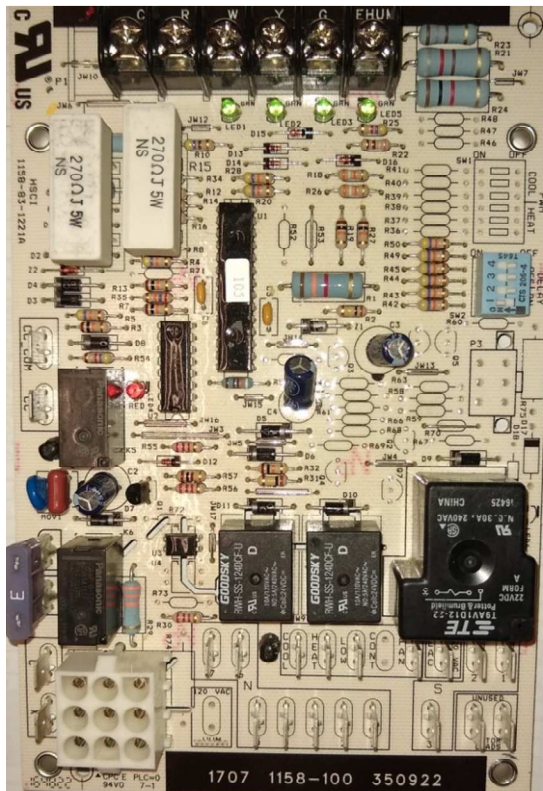

UT Fan Control Board

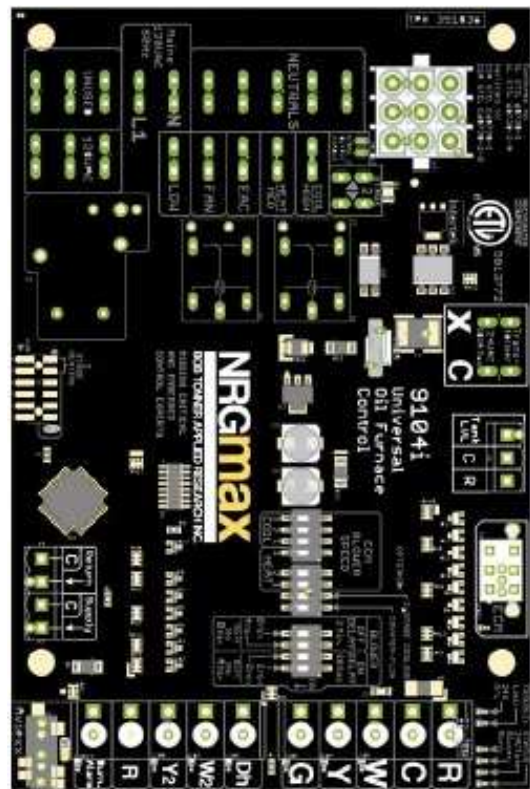

NRGmax Fan Control Board

Fig. 5: Fan Control Board

Note: For furnace models with an ECM Blower Motor Refer to ECM Operation Manual provided with those furnaces for ECM board information.

Operational modes

Standby Mode

All outputs are off and the control is waiting for a thermostat demand. The thermostat inputs, and limit switch are continuously monitored. The control initiates action when a thermostat call is received or limit switch opens.

Fan Mode

A call for fan (“G”) is received from the thermostat. If no other mode is calling for blower operation, the control will operate the fan relay and power the “Low” blower speed terminal. The fan mode will be operated as long as the “G” input is calling and neither the Heat mode nor the Cool mode is calling for blower operation. When the Heat and Cool modes call for blower operation, their respective outputs will take precedence after their respective turn-on time delays have expired.

Cooling Mode

- NRG Max Control - A call for cool (“Y”) is received from the thermostat. If the heat mode is not active the “COOL” speed blower terminal is energized. When the call for cool is satisfied, the “COOL” speed blower terminal is de-energized, the “HEAT” speed blower is energized and the blower off delay of 45 seconds is started. Forty-five seconds later the “HEAT” speed blower terminal is de-energized.
- UT Control Board - A call for cool (“Y”) is received from the thermostat. If the heat mode is not active or the anti-short cycle delay is not in effect, the control will energize the “CC” terminal and after a 10 second power demand conservation delay energizes the “COOL” speed blower terminal. When the call for cool is satisfied, the “CC” terminal is de-energized and the cooling off delay of 45 seconds is started. Forty-five seconds later the “COOL” speed blower terminal is de-energized. To prevent compressor short cycling, a call for cooling will be ignored for four minutes after the termination of any cooling call or at control power up.

Dehumidification Operation

If a call for dehumidification is received while the Cool Mode is active, blower speeds will be reduced. The “COOL” blower speed terminal will be de-energized and “Heat” blower speed (NRG Max Control) or “Low” (UT Control) will be energized.

EAC (electronic air cleaner)

If a call for fan (“G”), cool (“Y”) or heat (“W”) is received from the thermostat, the “EAC” terminal is energized whenever the blower is energized to power an electronic fan cleaner.

Heat Mode

When a call for heat (“W”) is received from the thermostat, if the “Cool” mode is not already active, the “T-T” terminal is energized and the blower on delay is started. When the delay time the “HEAT” blower speed is energized. The control remains in steady heat mode until the thermostat is satisfied. When the call for heat signal is removed, the “T-T” terminal is de-energized and the blower off delay is started. When the delay time has elapsed, the “HEAT” blower speed terminal is de-energized.

Blower On and Off Delays (Heat Mode Only)

Four Heat blower on and four blower off delays are selected by two dip switches for each function. Refer to wiring diagrams Appendix B for specific delay values.

Motor Blower Speed

Three interconnected blower speed outputs are provided. A “G” call for fan will provide power to the LOW speed tap only. A “W” heat call will provide power to the Heat speed tap only. A “Y” cooling call will provide power to the Cool speed tap only. The speed taps are interconnected and interlocked; only one speed may be powered at any one time.

Counterflow Operation

- NRG Max Control - Counterflow operation will only be allowed if “Options” Counterflow switch is in the ON position
- UT Control Board - Counterflow operation will only be allowed if JW10 is cut.

Counterflow Operation is only valid when a call for Heat is present. Counterflow Operation will bring the blower on at the “LOW” speed at a defined time between the enabling of the burner and the selected turn on time delay. Turn on delay times for the Counter Flow Operation is defined in Table 3. Once the selected Blower On Delay time has been reached, the blower operation will change to the operation described in Heat Mode section.

BLOWER ON DELAY DIP SWITCH SELECTION		COUNTERFLOW BLOWER ON DELAY
2	1	
OFF	OFF	15 Sec.
OFF	ON	24 Sec.
ON	OFF	36 Sec.
ON	ON	48 Sec.

Table 3: Counterflow Blower On Delay

Advanced Features (NRG Control only)

Tank Level, Refrigerant Temperature and Duct Sensor connections are for future use with a third party cloud based service called Aviexx. Contact Aviexx.com for more information.

Instructions to Our Customer / End User

! WARNING: If the burner does not operate properly after depressing the oil primary reset button, turn off the electrical power to the furnace and close the manual oil shutoff valve. Immediately contact a qualified heating contractor for service.

Before leaving a new installation, the installer should show the customer or end user where the furnace instruction manual is kept. He should also discuss the following points:

- 1) Describe the general operation of the furnace and, if properly equipped, the cooling system.
- 2) Show the location of the furnace air filter(s) and those in the duct system, if equipped. Demonstrate how to remove, clean, and replace the air filter(s).
- 3) Demonstrate how to set and adjust the room air temperature using the room thermostat.
- 4) Demonstrate how to operate (turn on and off), the heating system and, if properly equipped, the cooling system and the circulating air blower.
- 5) Show the location of the oil primary safety control in the furnace. Describe when and demonstrate how to depress the oil primary reset button.

SERVICE

Control Diagnostics

The control boards are equipped Input Status LEDs. These are intended to provide a quick view into furnace performance without requiring a voltmeter.

UT Control

- Normal Operation Indicators
Thermostat Inputs: Green LEDs indicate 24V signal present at terminal.
Status: Red LED is on solid to indicate valid input signal. In Standby Red LED is off.
- Fault LED Indicator
Limit: Red LED will flash rapidly while 120VAC is missing from the limit switch.

NRG Max Control

- Normal Operation Indicators
Thermostat Inputs: Amber LEDs indicate 24V signal present at terminal
Status: Blue LED pulses at various speeds to indicate operational state
24V Transformer: Green LED indicates that 24V transformer is powered
Blower: Green LED indicates Blower Relay is energized
Burner: Green LED indicates Burner TT Relay is energized
- Fault LED Indicator
Limit: Red LED indicates that High Limit is Open

Burner: Red Led indicates lockout alarm from Oil Burner (requires burner equipped with Lockout Alarm Function)

24V Over Load: Red LED indicates that an overload condition has caused the circuit protector to trip.

Troubleshooting

⚠ WARNING: When testing electrical equipment, always follow standard electrical safety procedures.

Before beginning these troubleshooting procedures, always review these basic points.

- 1) Check for 120 VAC power to the furnace. If there is no voltage, check the disconnecting switch for circuit breaker trip or blown fuses.
- 2) Make sure the room thermostat is set on the heating mode and is “calling for heat”.
- 3) Check for sufficient oil supply and that all oil shutoff valves are open.
- 4) To successfully service this oil furnace, the following recently (within the last year) calibrated instruments must be available.
 - Smoke spot test kit with Bacharach-type oil burner smoke scale
 - Carbon dioxide (CO₂) and carbon monoxide (CO) test kit or analyzer
 - Flue gas temperature measuring instrument
 - Draft gauge, capable of measuring 0.01 to 0.25 in. W.G. draft
 - Multimeter (analog or digital type)
 - Oil pressure gauge, capable of measuring at least 0 to 200 PSIG
- 5) Be familiar with the correct operation of these instruments as well as how to adjust the oil burner settings (refer to burner manufacturer’s literature).

A. Symptom: Furnace does not operate.

Items to check:

⚠ WARNING: Repeated operation of the oil primary safety control reset button can cause a build-up of unburned oil in the combustion chamber. An accumulation of oil in the combustion chamber is a hazardous situation and may cause a fire or explosion.

- 1) Make sure the disconnecting switch is “ON” and the circuit breaker has not tripped, or fuses have not blown.
- 2) Confirm there is 120 VAC at the junction box and the oil furnace control terminal S1.
- 3) Confirm the room thermostat is wired correctly, set on the “HEAT” mode, and “calling for heat”.
- 4) Refer to the oil burner manufacturer’s operating instructions (included with the furnace) for primary control troubleshooting

B. Symptom: Burner short cycles on high limit thermostat, but does not “lock out” on oil primary safety control.

Items to check:

- 1) Open dampers or registers in the air distribution system. Clear any duct system restrictions.
- 2) Inspect and clean all air filters in the air distribution system.
- 3) Inspect blower for interference with rotation or locked rotor condition. Also, confirm the blower wheel is secured to the fan motor shaft.
- 4) The fan motor or run capacitor may be damaged. Test and replace the motor or capacitor, as required.
- 5) Increase fan speed.

C. Symptom: Burner short cycles on high limit thermostat, but does not “lock out” on oil primary safety control.

Items to check:

- 1) Open dampers or registers in the air distribution system. Clear any duct system restrictions.
- 2) Inspect and clean all air filters in the air distribution system.
- 3) Inspect blower for interference with rotation or locked rotor condition. Also, confirm the blower wheel is secured to the fan motor shaft.
- 4) The fan motor or run capacitor may be damaged. Test and replace the motor or capacitor, as required.
- 5) Increase fan speed.
- 6) Measure the draft at the point where the vent connector attaches to the heat exchanger flue pipe. With the burner operating, the stack draft should not exceed 0.05 in. W.G. If the stack draft has been adjusted above this value to give the proper overfire draft, the heat exchanger will require cleaning. If there is little or no stack draft, the chimney flue way may require cleaning, the chimney is too restrictive, or a downdraft condition exists.

D. Symptom: Furnace blower will not start.

Items to check:

- 1) Confirm there is 120 VAC at the blower terminal labeled “HEAT” on the oil furnace control.
- 2) If there **is not** 120 VAC at the blower motor terminal, measure the voltage at the S1 terminal on the oil furnace control. If the fan can be activated by itself from the room thermostat subbase, confirm it will operate. If so, the oil furnace control may have a burnt or damaged relay. Confirm and replace the control if necessary.
- 3) If there **is** 120 VAC at the blower motor terminal “HEAT”, either the run capacitor or blower motor may be damaged. Test and replace the capacitor or motor, as required.

E. **Symptom: Blower cycles on and off after the burner has shutdown.**

Item to check:

- 1) Increase the fan off time by changing the DIP switch selections on SW2. Refer to Table 2 for blower delay off settings.

NOTICE: If the high limit control is faulty, it should be replaced. However, it must only be replaced by the same make and model as the original. Refer to the electrical diagrams for proper electrical connections.

Flame Sensor (“Cad Cell”) Checkout Procedure

Refer to the oil burner manufacturer’s operating instructions (included with the furnace) for detailed cad cell troubleshooting.

Replacement Parts

Appendix D of this manual contains a list of replacement parts available for these furnaces.

MAINTENANCE

Air Filter(s)

⚠ CAUTION: To avoid injury from moving parts, hot surfaces, or electrical shock, shut off the power to the furnace and allow the furnace to cool BEFORE removing any furnace access doors to service air filters.

These furnace models are factory-supplied with a permanent-type, air filter. At least twice a year, remove the air filter(s) for cleaning. Clean a filter by soaking it in water with a mild detergent and then rinsing it with clean water. Allow the filter to air dry before reinstalling it in the furnace filter rack.

If the furnace, or duct system, is equipped with disposable-type (paper element), air filters, inspect them every month for an excessive accumulation of dust and dirt. Replace disposable air filters at least twice a year. Make certain the replacement filter is the same size as the one being replaced. The filter size is marked on the outer edge of the air filter. Install the filter with the arrow marked on the filter pointing toward the furnace.

Oil Burner

NOTICE: A qualified heating contractor MUST service the oil burner in this furnace at least once a year.

Generally, service to the burner will involve a thorough inspection and cleaning of the burner, replacement of the oil nozzle and oil filter, and readjustment of the burner to achieve proper ignition and clean combustion.

Blower and Motor

NOTICE: The fan motor has sealed bearings that do NOT require lubrication.

The blower and fan motor will **not** normally require any service. This furnace is equipped with a directly-driven blower. Therefore, it will **not** require any retensioning or replacement of a drive belt.

Heat Exchanger

⚠ CAUTION: DO NOT attempt to clean the heat exchanger unless electrical power and fuel flow to the furnace are turned off.

⚠ CAUTION: The combustion chamber refractory material is fragile and can be easily damaged. Carefully remove the chamber from the heat exchanger before attempting to clean the inner drum.

NOTICE: A qualified heating contractor MUST inspect the heat exchanger in this furnace at least once a year. If heavy deposits are found, immediate cleaning is required.

All heat exchanger surfaces should be as clean as possible for the most efficient operation of the furnace. The heat exchanger may require cleaning after every heating season, as combustion of fuel oil tends to produce soot, particulate matter, and scale, due to corrosion.

NOTICE: Accumulation of heavy soot deposits over one heating season may indicate the oil burner is out of adjustment.

The heat exchanger may be inspected and cleaned through an access, or cleanout, port located in the burner compartment. Remove clean-out plugs, the vent connector pipe to the chimney, the burner, and the burner mounting plates. When removing the clean-out plugs, turn T-handle counterclockwise approximately two (2) full turns or just until the plug is able to be pulled from tube. Take care not to remove T-handle from assembly. See Fig. 6.

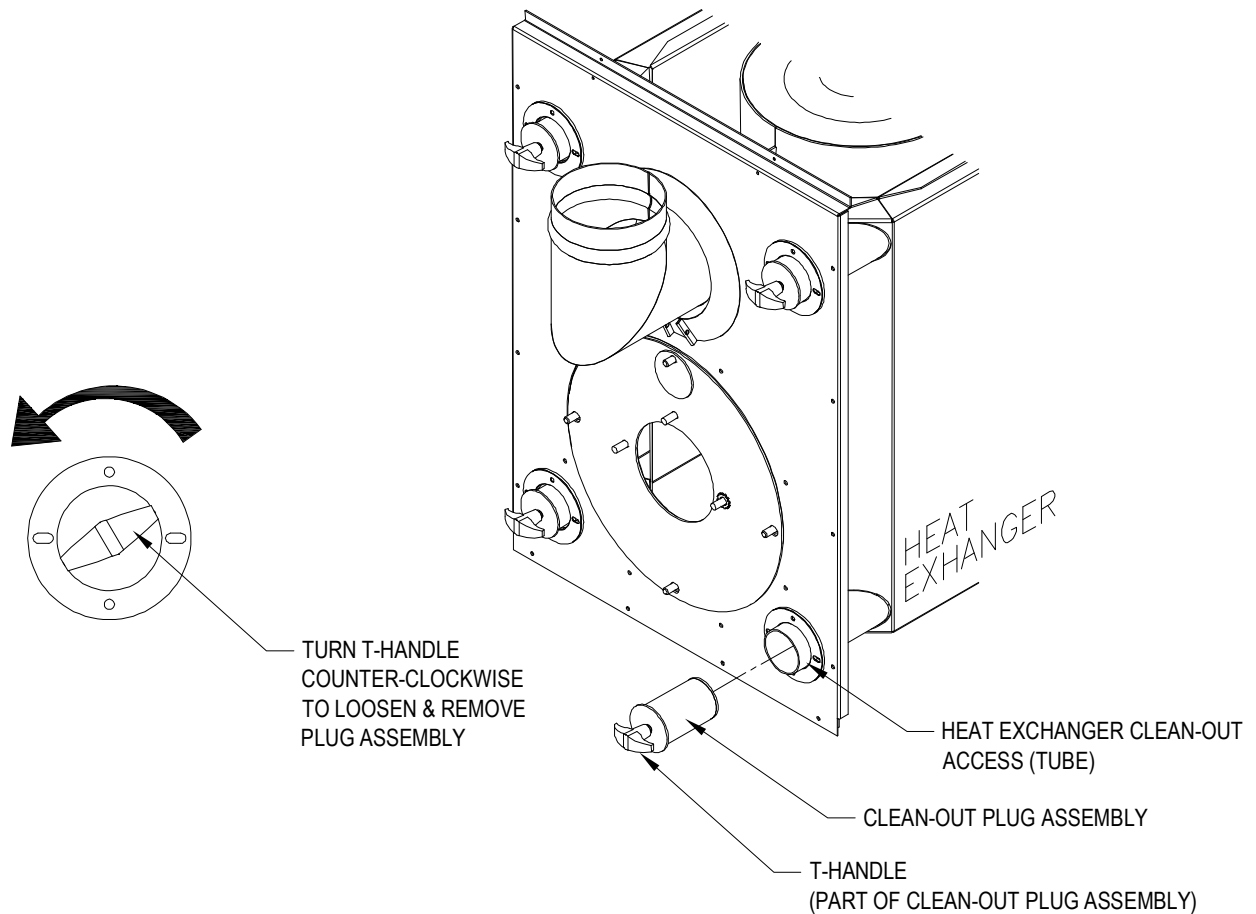

Figure 6: Location and Design of Heat Exchanger Cleanout Port

With access to the inside of the heat exchanger through the burner area, clean-out openings, and vent pipe connection, it is possible to use a long, flexible wire brush and an industrial type vacuum cleaner to remove any soot build-up. NOTE: A one inch (outside diameter) vacuum cleaner hose will fit into the radiator, approximately 8' will be needed to reach completely around and into the front area between the cleanout ports.

To vacuum and brush the outer radiator of the heat exchanger, go through the clean-out openings in both directions.

Flue and Chimney

At least once a year, thoroughly inspect the heat exchanger flue pipe, the vent connector, the chimney, or vent, and the barometric damper for signs of sagging, loose connections, excessive corrosion, and deterioration. Clean, repair, or replace any components for continued safe and proper operation of the furnace.

USERS INFORMATION

⚠ IMPORTANT: This furnace must be serviced annually by a licensed professional technician, or equivalent.

⚠ WARNING:

- The area around the furnace should be kept free and clear of flammable vapors, liquids, and material, especially papers and rags.
- NEVER burn garbage or refuse in the furnace. NEVER try to ignite oil by tossing burning papers or other material into the furnace.
- This oil furnace is designed to burn No. 2 distillate fuel (home heating) oil ONLY. NEVER USE GASOLINE OR A MIXTURE OF OIL AND GASOLINE.
- DO NOT attempt to make repairs to the furnace yourself!

Operating Instructions

For your safety, read this information before operating this furnace.

⚠ WARNING: Failure to follow these instructions may result in fire or explosion causing property damage, personal injury, or loss of life.

WHAT TO DO IN THE EVENT OF AN OIL LEAK:

- Do not try to operate this or any other nearby appliance.
- If present, close the manual oil shutoff valve on the fuel oil supply line.
- Immediately call a qualified heating contractor for service.
- If you cannot reach a qualified heating contractor, call the fuel oil supplier or the fire department.

DO NOT use this furnace if any component was underwater. Immediately call a qualified heating contractor to inspect the furnace and replace any part of the furnace control system that was underwater.

This furnace does not have a pilot light. It is equipped with an electronic ignition system that automatically lights the burner. DO NOT attempt to light the burner by hand.

TO OPERATE THIS FURNACE:

- 1) Adjust the room thermostat to the lowest set point and set the operating mode, if equipped, to "OFF".
- 2) Turn the manual oil shutoff valve to the open or "ON" position.
- 3) This furnace is equipped with an electronic ignition system that automatically lights the burner. DO NOT try to light the burner by hand.
- 4) Turn on the electric power to the furnace at the disconnecting switch.
- 5) Adjust the room thermostat to the desired set point and set the operating mode, if equipped, to "HEAT".
- 6) If the furnace will not operate, call a qualified heating contractor for service.

TO INTERRUPT (STOP) OPERATION OF THIS FURNACE:

- 1) Adjust the room thermostat to the lowest set point and set the operating mode, if equipped, to "OFF".
- 2) If service will be performed, turn off all electric power to the furnace at the disconnecting switch.
- 3) Turn the manual oil shutoff valve to the closed or "OFF" position.

Oil Supply

This oil furnace is designed to use No. 2 or lighter distillate fuel (home heating) oil. A Bio-fuel mixture may be used but the mixture is not to exceed a B5.

- DO NOT allow the fuel tank to run completely dry during the heating season. If the fuel tank runs completely dry, it may be necessary to purge the oil lines of trapped air.
- During the warmer weather, **keep the tank full** to prevent condensation of moisture on the inside surface of the tank.
- **Keep the cap on the fuel tank** fill pipe tightly closed at all times to prevent the entrance of moisture, foreign matter, insects, etc. Also, check the tank, vent, and fill pipe for cracks and leaks.

Extended Shutdown

If the furnace will be shut down for an extended period of time:

- 1) Adjust the room thermostat to the lowest set point and set the operating mode, if equipped, to "OFF".
- 2) Open the disconnecting switch serving the furnace.
- 3) Close the manual oil shutoff valve.

Combustion and Ventilation Air Supply

The furnace and venting system require a generous amount of clean air to operate safely. Lack of adequate combustion and ventilation air can result in erratic operation of the burner, noisy and poor combustion, sooting of the combustion chamber, and fuel odors in the air. **Never block off or restrict the supply of air to the furnace.**

Inspection Areas

Burner Compartment: On the counterflow / horizontal furnace models, the burner compartment can be inspected by removing the front door of the furnace. Look for signs of excessive heat, such as discoloration of components, damage to material from rust or corrosion, soot or carbon build-up, and evidence of fuel oil leakage.

Exterior of Furnace: The exterior of the furnace should be inspected for signs of excessive heat such as discoloration of materials and damage from rust or corrosion. Confirm the base or frame supporting the furnace is level and in sound condition.

Venting System: The furnace flue pipe, vent connector, barometric damper, and chimney should be inspected for:

- Signs of excessive rust, corrosion pitting, and holes.
- Signs of condensation or moisture leakage.
- Evidence of structural damage, and loose or disconnected piping joints.
- Presence animal nests.
- Free movement of the vane of the barometric damper without binding or interference.

If any problems are evident, call a qualified heating contractor for assistance.

NOTICE: A qualified heating contractor MUST service the oil burner and inspect the heat exchanger in this furnace at least once a year.

APPENDIX A: STARTUP SHEET

Combustion and Efficiency Testing for Oil Fired Furnaces:

Complete this form for each oil furnace installed. Read instruction manual carefully before taking test. Retain this form with furnace.

CUSTOMER	NAME				
	ADDRESS				
	CITY, STATE				
HEATING SYSTEM	FURNACE MODEL				
	FURNACE SERIAL				
	BURNER MODEL NO.				
	TYPE OF VENTING & OIL SYSTEM (CHECK ALL THAT APPLY)				
	<input type="checkbox"/> MASONRY CHIMNEY	<input type="checkbox"/> CLAY LINER	<input type="checkbox"/> MAKE UP AIR TO MECHANICAL ROOM		
	<input type="checkbox"/> METAL CHIMNEY	<input type="checkbox"/> METAL LINER	<input type="checkbox"/> DIRECT VENT		
	<input type="checkbox"/> DRAFT CONTROL	<input type="checkbox"/> SIDEWALL POWER VENTER	<input type="checkbox"/> COMBUSTION AIR KIT		
COMBUSTION TEST Operate burner for at least 10 min. before taking readings.		INITIAL	SERVICE	SERVICE	SERVICE
	CO ₂ (%)				
	O ₂ (%)				
	CO (PPM)				
	SMOKE NO.				
	DRAFT - BREECH (IN W.C.)				
	DRAFT - OVERFIRE (IN W.C.)				
	GROSS FLUE TEMP (°F)				
	ROOM TEMP (°F)				
	EFFICIENCY (%)				
	SUPPLY TEMP (°F)				
	RETURN TEMP (°F)				
	TEMP RISE (°F)				
	NOZZLE (GPH/ANGLE/CONE)				
	PUMP PRESS (PSI)				
	SAFTEY CONTROL OPERATION				
	CHECK FOR LEAKS				
	TECHNICIAN				
	DATE				
	INSTALLER	NAME		ADDRESS	

APPENDIX B: ELECTRICAL DIAGRAMS

OD6*FAO72D48

(NRGMAX CONTROL)

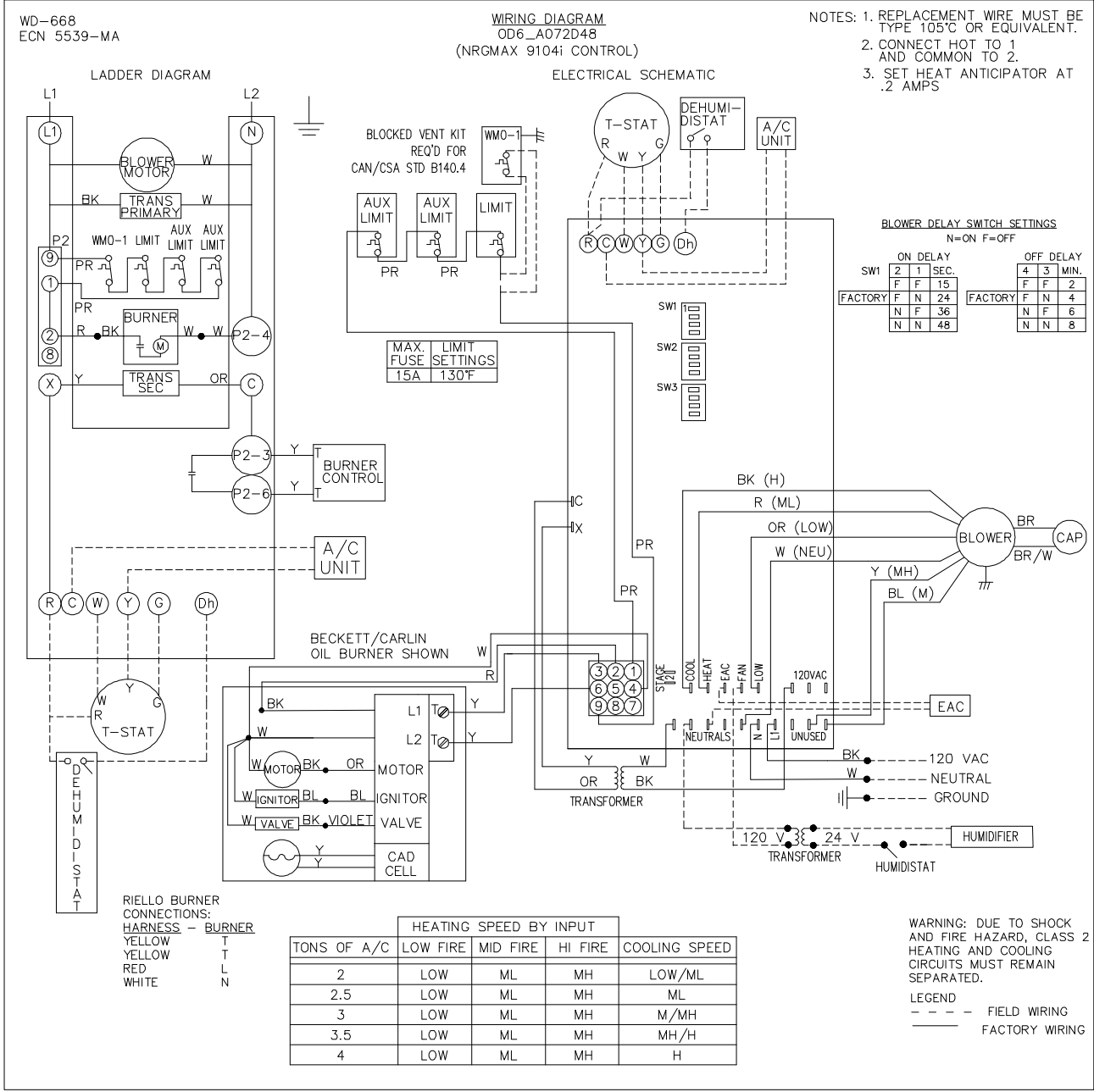

OD6*FA072DV5 (NRGMAX CONTROL)

WD-670
ECN 5539-MA

WIRING DIAGRAM
OD6_A072DV5
(NRGMAX 9104i CONTROL)

- NOTES: 1. REPLACEMENT WIRE MUST BE TYPE 105°C OR EQUIVALENT.
2. CONNECT HOT TO 1 AND COMMON TO 2.
3. SET HEAT ANTICIPATOR AT .2 AMPS

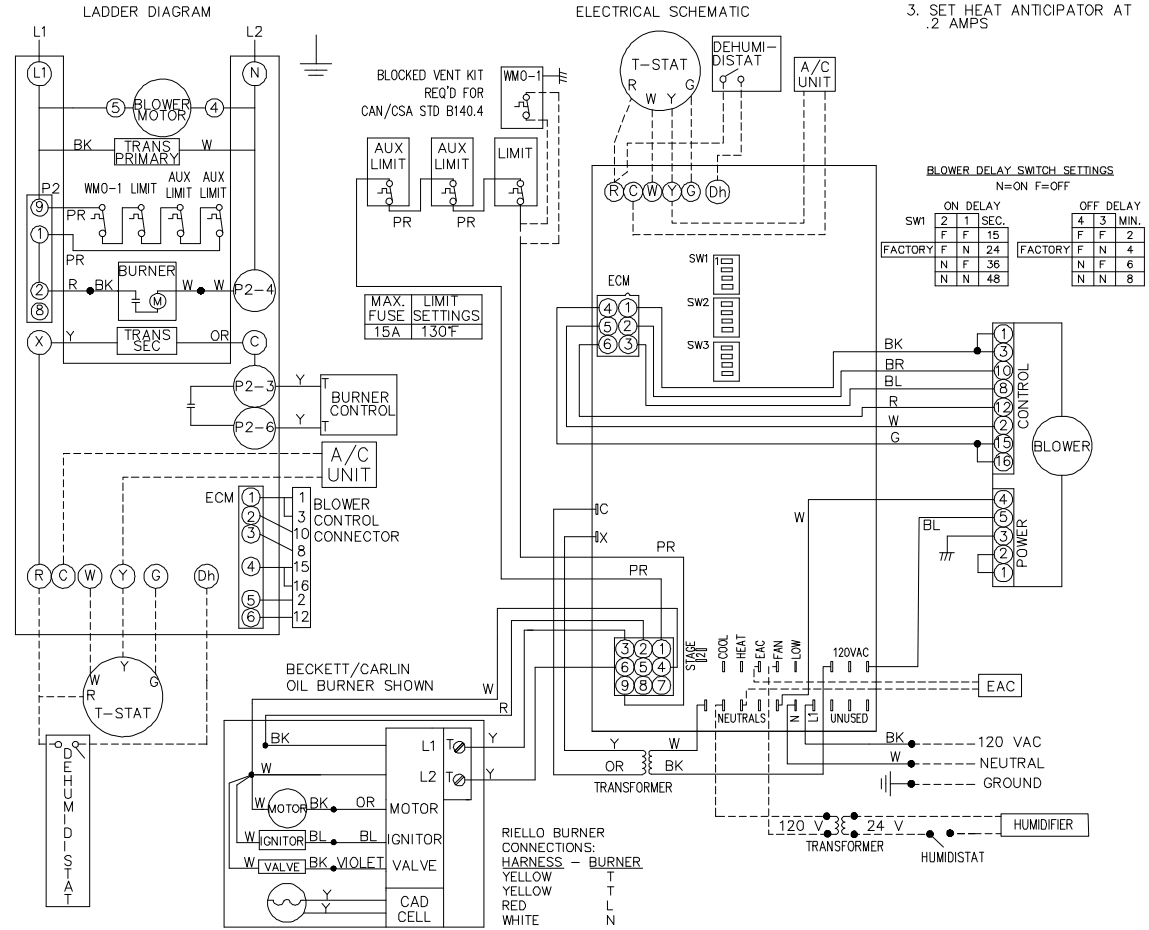

BLOWER DELAY SWITCH SETTINGS
N=ON F=OFF

ON DELAY		OFF DELAY	
SW1	2 1 SEC.	F 3	MIN.
FACTORY	F N 15	F N 2	
	N F 24	N N 4	
	N F 36	N F 6	
	N N 48	N N 8	

HEATING SPEED SET-UPS

ECM BLOWER HEAT SWITCH SETTINGS	BTUH	HEATING SPEED SET-UPS		
		LOW FIRE 60,000	MED FIRE 72,000	HI FIRE 90,000
3-OFF 2-OFF 1-OFF	755	APPROX. RISE (°F) 73°F		
3-OFF 2-OFF 1-ON	826	66°F	80°F	
3-OFF 2-ON 1-OFF	898	61°F	74°F	
FACTORY HEAT SWITCH SETTINGS	983	56°F	67°F	84°F
3-ON 2-OFF 1-OFF	1068		62°F	77°F
3-ON 2-OFF 1-ON	1168		57°F	71°F
3-ON 2-ON 1-OFF	1282			64°F
3-ON 2-ON 1-ON	1424			58°F

COOLING SPEED SET-UPS

ECM BLOWER COOL SWITCH SETTINGS	COOLING TONNAGE	AIR FLOW	
		COOL	CONTINUOUS
3-OFF 2-OFF 1-OFF	2	799	500
3-OFF 2-OFF 1-ON	2.5	1017	508
3-OFF 2-ON 1-OFF	3	1210	605
3-OFF 2-ON 1-ON	3.5	1404	702
FACTORY COOL SWITCH SETTINGS	4	1622	799
3-ON 2-OFF 1-OFF	5	2010	993

WARNING: DUE TO SHOCK AND FIRE HAZARD, CLASS 2 HEATING AND COOLING CIRCUITS MUST REMAIN SEPARATED.
LEGEND
- - - FIELD WIRING
- - - FACTORY WIRING

OD6*FA072D48 (UT CONTROL)

WD-583
ECN 5539-MA

WIRING DIAGRAM
OD6_A072D48
(UT 1158-100 CONTROL)

- NOTES: 1. REPLACEMENT WIRE MUST BE TYPE 105°C OR EQUIVALENT.
2. CONNECT HOT TO 1 AND COMMON TO 2.
3. SET HEAT ANTICIPATOR AT .2 AMPS

L1 LADDER DIAGRAM L2

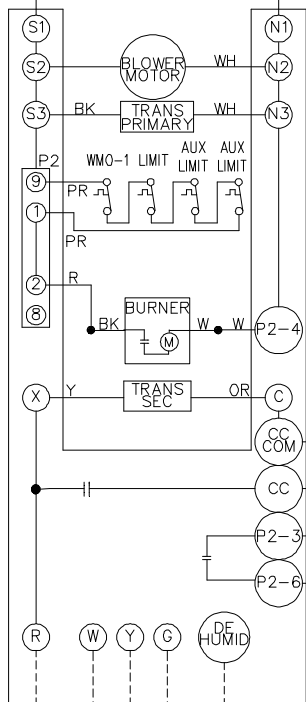

ELECTRICAL SCHEMATIC

BLOCKED VENT KIT
REQ'D FOR
CAN/CSA STD B140.4

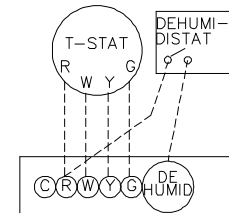
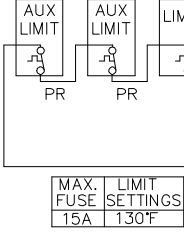

BLOWER DELAY SW2 SWITCH SETTINGS
N=ON F=OFF

SW2	ON DELAY			OFF DELAY		
	2	1	SEC.	4	3	MIN.
FACTORY	F	F	15	F	F	2
	F	N	24	F	N	4
	N	F	36	N	F	6
	N	N	48	N	N	8

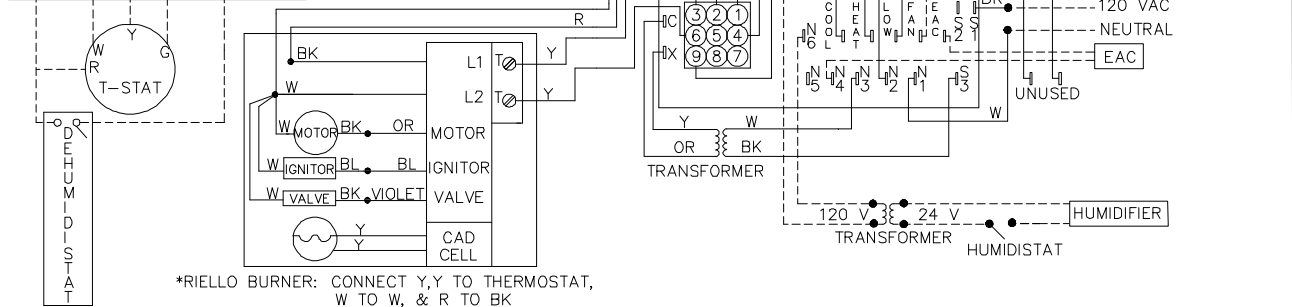

*RIELLO BURNER: CONNECT Y,Y TO THERMOSTAT,
W TO W, & R TO BK

TONS OF A/C	HEATING SPEED BY INPUT			COOLING SPEED
	LOW FIRE	MID FIRE	HI FIRE	
2	LOW	ML	MH	LOW/ML
2.5	LOW	ML	MH	ML
3	LOW	ML	MH	M/MH
3.5	LOW	ML	MH	MH/H
4	LOW	ML	MH	H

WARNING: DUE TO SHOCK AND FIRE HAZARD, CLASS 2 HEATING AND COOLING CIRCUITS MUST REMAIN SEPARATED.

LEGEND
- - - FIELD WIRING
_____ FACTORY WIRING

OD6*FA072DV5 (UT CONTROL)

WD-584
ECN 5539-MA

WIRING DIAGRAM
OD6_A072DV5
(UT 1158-101 CONTROL)

- NOTES: 1. REPLACEMENT WIRE MUST BE TYPE 105°C OR EQUIVALENT.
2. CONNECT HOT TO 1 AND COMMON TO 2.
3. SET HEAT ANTICIPATOR AT .2 AMPS

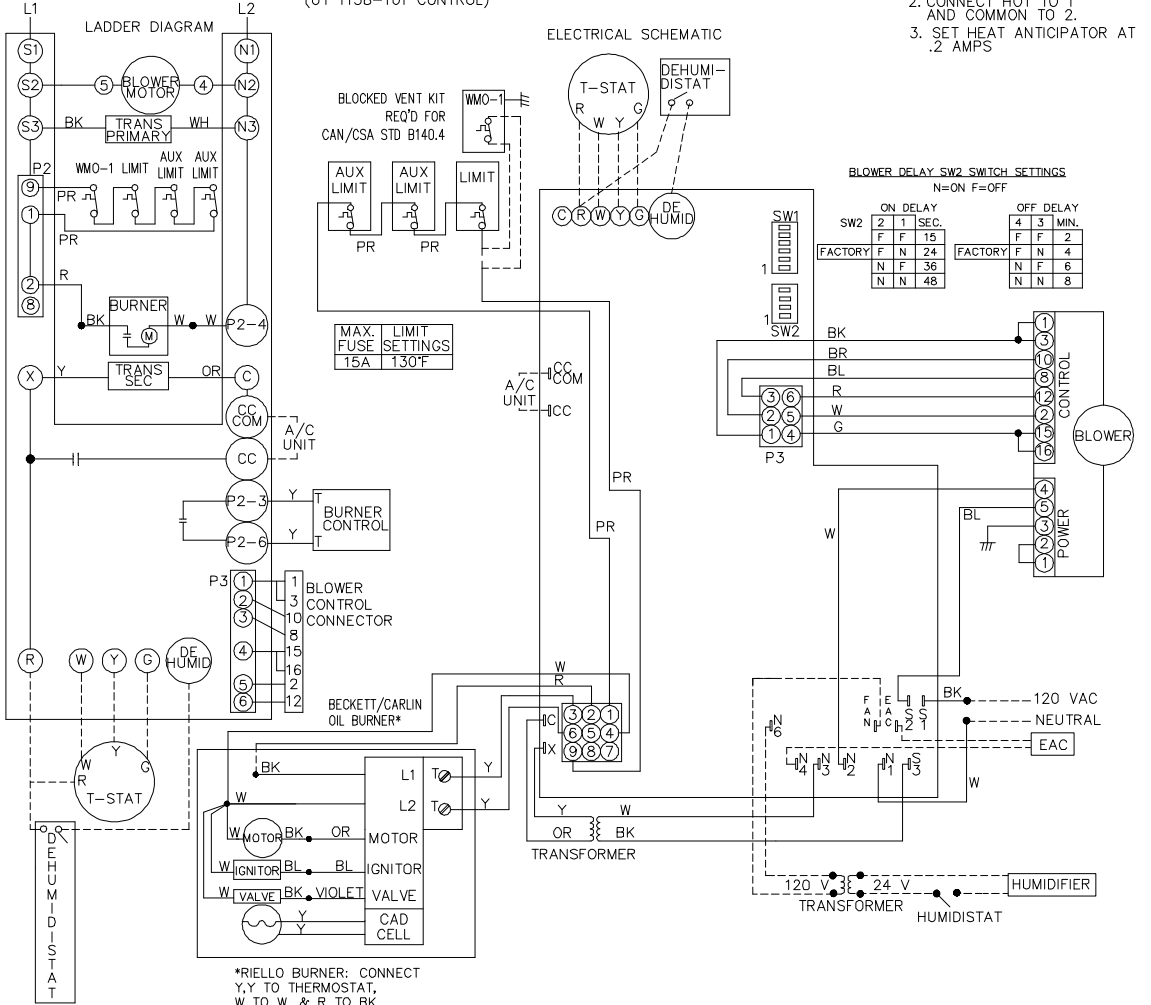

HEATING SPEED SET-UPS

FAN CONTROL SW 1 SWITCH SETTINGS	BTUH	HEATING SPEED SET-UPS		
		LOW FIRE 60,000	MED FIRE 72,000	HI FIRE 90,000
3-OFF 2-OFF 1-OFF	755	APPROX. RISE (°F) 73°F		
3-OFF 2-OFF 1-ON	826	66°F	80°F	
3-OFF 2-ON 1-OFF	898	61°F	74°F	
FACTORY SW1 SWITCH SETTINGS				
3-OFF 2-ON 1-ON	983	56°F	67°F	84°F
3-ON 2-OFF 1-OFF	1068		62°F	77°F
3-ON 2-OFF 1-ON	1168		57°F	71°F
3-ON 2-ON 1-OFF	1282			64°F
3-ON 2-ON 1-ON	1424			58°F

COOLING SPEED SET-UPS

FAN CONTROL SW 1 SWITCH SETTINGS	COOLING TONNAGE	AIR FLOW	
		COOL	CONTINUOUS
6-OFF 5-OFF 4-OFF	2	799	500
6-OFF 5-OFF 4-ON	2.5	1017	508
6-OFF 5-ON 4-OFF	3	1210	605
6-OFF 5-ON 4-ON	3.5	1404	702
FACTORY SW1 SWITCH SETTINGS			
6-ON 5-OFF 4-OFF	4	1622	799
6-ON 5-ON 4-OFF	5	2010	993

WARNING: DUE TO SHOCK AND FIRE HAZARD, CLASS 2 HEATING AND COOLING CIRCUITS MUST REMAIN SEPARATED.

LEGEND
- - - - - FIELD WIRING
_____ FACTORY WIRING

APPENDIX C: SPECIFICATION SHEETS

MODEL NO.	OD6*A072D48 B OD6*A072DV5 B			OD6*A072D48 C OD6*A072DV5 C			OD6*A072D48 R OD6*A072DV5 R		
HEAT INPUT RATE (BTUH)	106,250	85,000	70,000	106,250	85,000	70,000	106,250	85,000	70,000
OUTPUT BTUH [1]	89,000	72,000	60,000	89,000	72,000	60,000	89,000	72,000	60,000
AFUE % [2]	85.7 [3]			85.0 [3]			85.7 [3]		
LARGEST REC A/C (Tons)	4 (D48) - 5 (DV5)								
NOMINAL TEMP RISE (° F)	66								
CASING WIDTH (IN.)	20								
CASING DEPTH (IN.)	30								
CASING HEIGHT (IN.)	45								
NOMINAL FLUE OUTLET DIA. (IN.)	5								
APPROX SHIPPING WEIGHT (LBS)	250								
QTY & SIZE OF PERM. FILTERS (IN.)	(2) 13 X 19								
ELECTRICAL REQUIREMENTS	120v/ 60hz/ 1ph								
TOTAL CURRENT (AMPS) PSC/ECM	8.7/12.3								
MAX FUSE SIZE (AMPS)	15								
HEIGHT, FLOOR - CENTER OF FLUE	20.5								
SUPPLY AIR OUTLET SIZE (IN.)	18 W X 20 D								
RETURN AIR INLET SIZE (IN.)	18 W x 19 D								
BURNER MODEL	BECKETT AFG			CARLIN EZ-1HP			RIELLO BF3		
AIR TUBE LENGTH (IN.)	4.5, effective			4.5, effective			4.5, effective		
BURNER HEAD TYPE	Fixed, flame retention			NA			NA		
HEAD POSITIONING BAR	NA	NA	NA	NA	.85-1.0	0.75	NA	NA	NA
NOZZLE (GPH)	0.75	0.60	0.50	0.75	0.60	0.50	0.70	0.60	0.50
CO2 % (Typical Range)	11.5-12	11-11.5	10.5-11	11.5-12	11-11.5	10.5-11	11.5-12	11-11.5	10.5-11
OVERFIRE DRAFT "W.C. (-.03@ Flue)	+0.015	+0.005	0	+0.015	+0.005	0	+0.015	+0.005	0
SMOKE	0			0			0		
SPRAY ANGLE (Deg.)	70			60			80		
SPRAY PATTERN:	Solid (B)	Solid (B)	Hollow (A)	Hollow (A)			Hollow (A)		
OIL PUMP PRESSURE (PSIG)	120			120			140		
IGNITION CONTROL TYPE	Interrupted, Direct Spark			Interrupted, Direct Spark			Interrupted, Direct Spark		
CONTROL TIMING PRE / POST (Sec.)	15 / 0			15 / 0			10 / 0		
COMBUSTION CHAMBER TYPE	Preformed, refractory (ceramic fiber matrix material)								
MINIMUM CLEARANCES TO COMBUSTIBLE MATERIALS									
SIDES (IN.)	0								
TOP (IN.)	1								
FRONT (IN.)	6								
REAR (IN.)	0								
FLUE/VENT PIPE (IN.)	7								
SUPPLY PLENUM (IN.)	1								

1 OUTPUT BTUH BASED ON ANNUAL FUEL UTILIZATION EFFICIENCY RATED BY MANUFACTURER.

2 ANNUAL FUEL UTILIZATION EFFICIENCY RATINGS ARE BASED ON TESTS FOLLOWING U.S. DEPARTMENT OF ENERGY TEST PROCEDURES.

3 AFUE RATINGS AS SHIPPED AT 105,000 BTU INPUT.

APPENDIX D: REPLACEMENT PARTS

OD6FA072D48, OD6FA072DV4

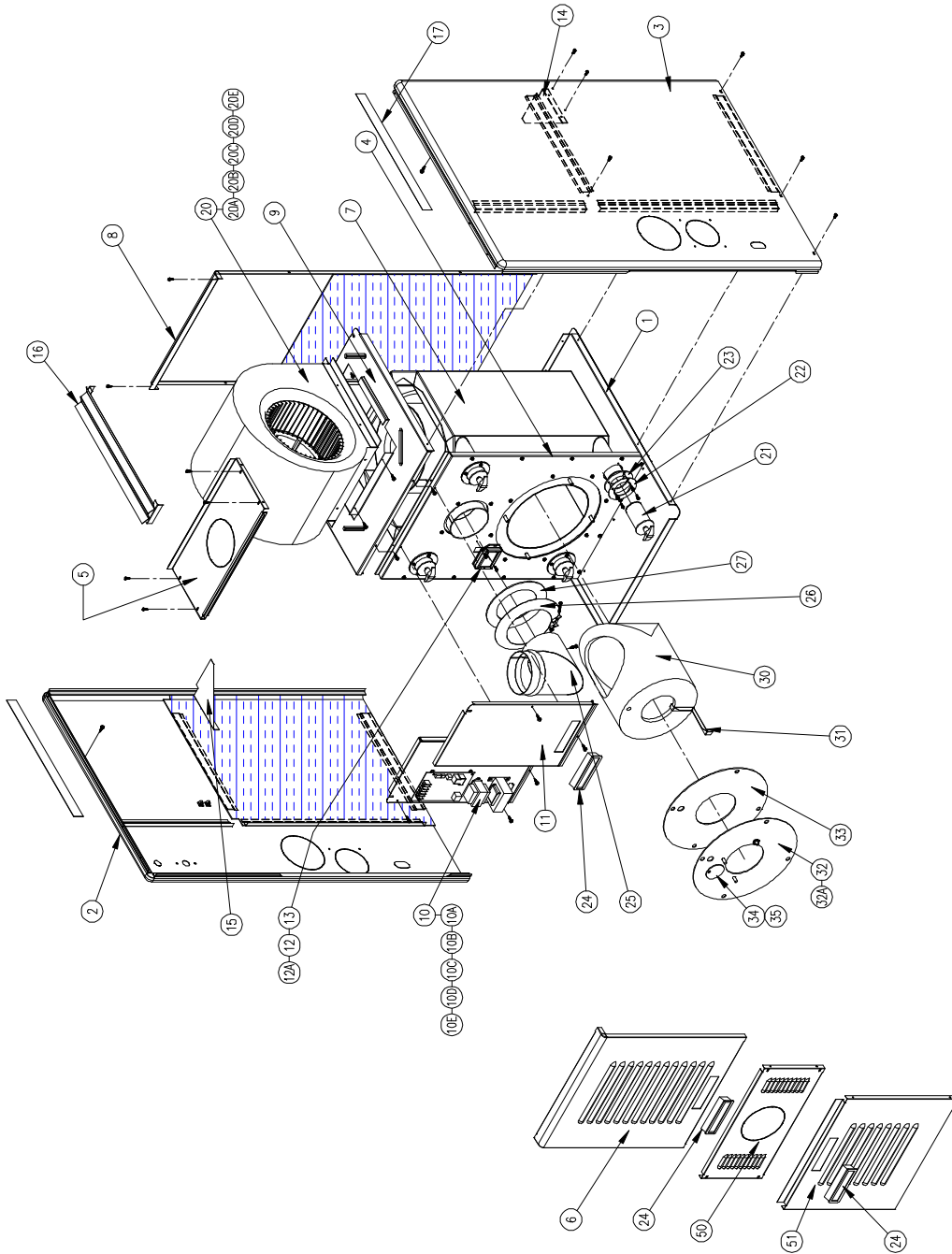
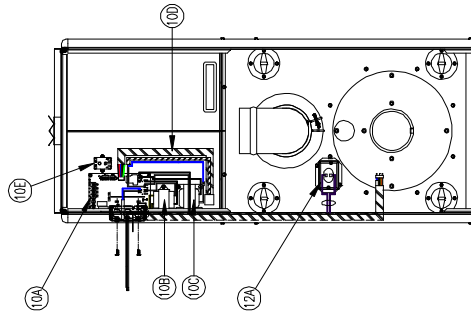

ITEM	PARTS DESCRIPTION	MODEL NO.		OD6FA072DV5	
		OD6FA072D48	OD6FA072DV5	PART NO.	QTY.
1	BASE	18648	1	18648	1
2	CASING, LEFT SIDE	628645	1	628645	1
3	CASING, RIGHT SIDE	628646	1	628646	1
4	PANEL, FRONT SEPARATOR	618639	1	618639	1
5	PANEL, TOP FRONT	628641	1	628641	1
6	FRONT TOP PANEL	618714	1	618714	1
7	HEAT EXCHANGER	38626	1	38626	1
	HEAT EXCHANGER, GASKET KIT	AOPS7704	1	AOPS7704	1
8	CASING, BACK	618642	1	618642	1
9	BLOWER PAN	18647	1	18647	1
10	CONTROL PANEL, SUB-ASSEMBLY	S00S4475	1	S00S4476	1
11	CONTROL, FAN TIMER	50089	1	50089	1
12	TRANSFORMER 24v	350405	1	350405	1
13	HARNESS, VESTIBULE	350329	1	350326	1
14	PANEL, BLOWER ACCESS (RIGHT)	19227	1	19227	1
15	BRACKET, LIMIT SPACER	18652	1	18652	1
16	LIMIT SWITCH	350783	1	350783	1
17	GASKET	330119	1	330119	1
18	BAFFLE, RIGHT SIDE CASING	18460	1	18460	1
19	BAFFLE, LEFT SIDE CASING	18461	1	18461	1
20	FILTER RACK	628651	1	628651	1
21	PLENUM STRIP, 18.750	618462	2	618462	2
22	PLENUM ANGLE, 19.75"	18653	2	18653	2
23	PLENUM ANGLE, 17.75"	18309	2	18309	2
24	BLOWER SUB-ASSEMBLY	S00S4158	1	S00S4159	1
25	BLOWER HOUSING 120-9T W/ WHEEL	340042	1	340042	1
26	BLOWER WHEEL	340108	1	340108	1
27	MOTOR MTG BRACKET ASSEMBLY	AOPS7670	1	AOPS7670	1
28	MOTOR REPLACEMENT KIT	AOPS7652	1	AOPS7474	1
29	MOTOR	-	-	350256	1
30	16x4 BOX PROGRAMMED	-	-	AOPS7506	1
31	HARNESS, 16x4 BOX	-	-	350259	1
32	AUXILIARY LIMIT SWITCH	350891	2	350891	2
33	CAPACITOR 10 MFD 370 V	350073	1	-	-
34	HARNESS, BLOWER COMPARTMENT	350330	1	350327	1
35	CLEAN-OUT PLUG ASSEMBLY	S00S4489	4	S00S4489	4
	HIGH TEMP HOSE	19178	4	19178	4
36	TRIM PLATE, CLEAN-OUT	18553	4	18553	4
37	GASKET, TRIM PLATE	330215	4	330215	4
38	DOOR PULL	320157	3	320157	3
39	5" ELBOW (LOW-PROFILE)	36050	1	36050	1
40	DRAW COLLAR	14121	1	14121	1
41	GASKET, FLUE COLLAR	330073	1	330073	1
42	COMBUSTION CHAMBER	AOPS7492	1	AOPS7492	1
43	CHAMBER RETAINER	18557	1	18557	1
44	PLATE, BURNER MOUNTING ASS'Y	AOPS7597	1	AOPS7597	1
45	GASKET, BURNER MOUNTING PLATE	330212	1	330212	1
46	COVER, OVER-FIRE DRAFT OPENING	18556	1	18556	1
47	GASKET, OFDO COVER	330343	1	330343	1
48	DRAFT CONTROL	370110	1	370110	1
49	FILTER, 13"x19"x1"	370041	2	370041	2
50	FRONT CENTER PANEL	618715	1	618715	1
51	FRONT BOTTOM PANEL	628716	1	628716	1

OD6RA072D48, OD6RA072DV4

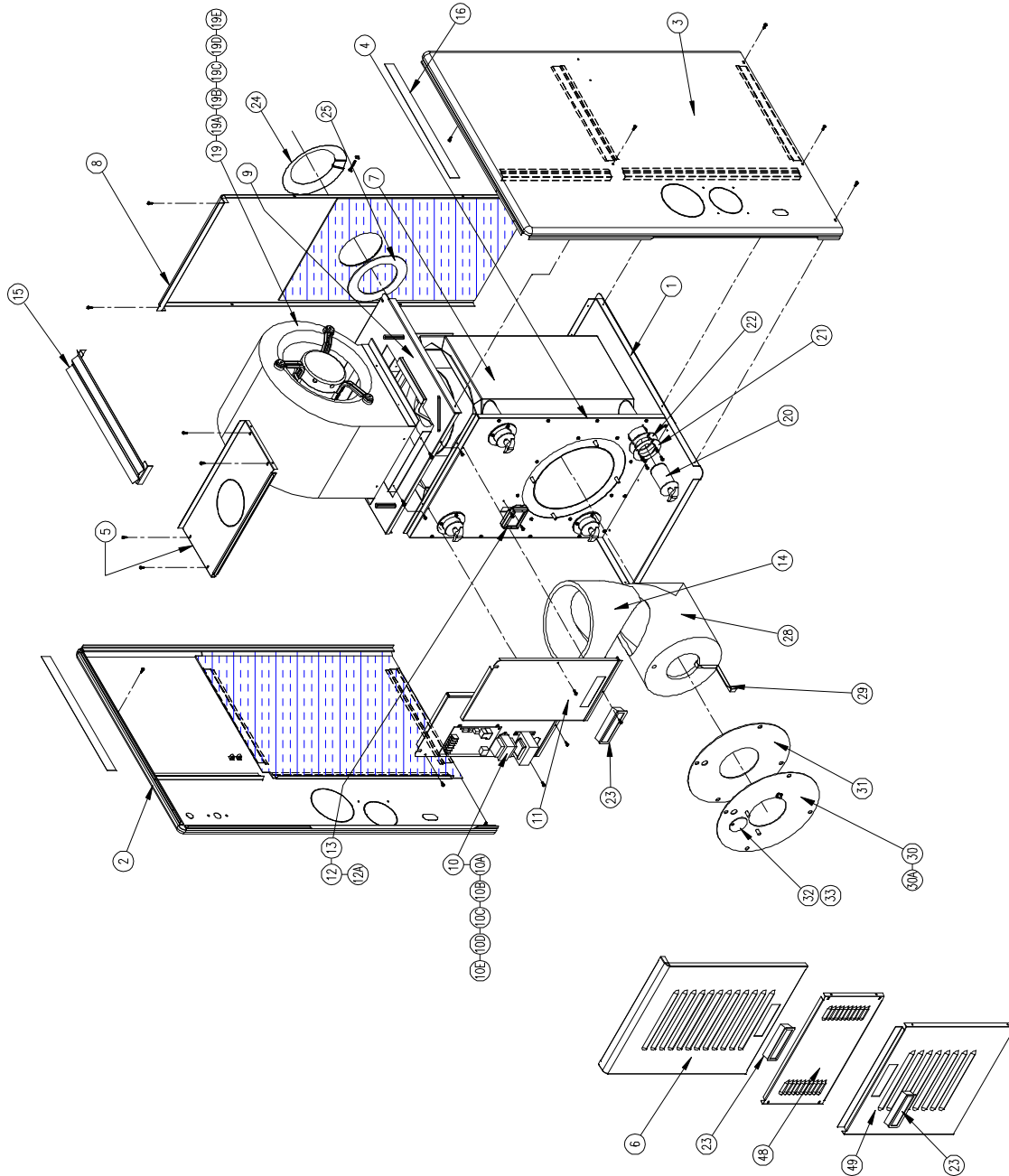
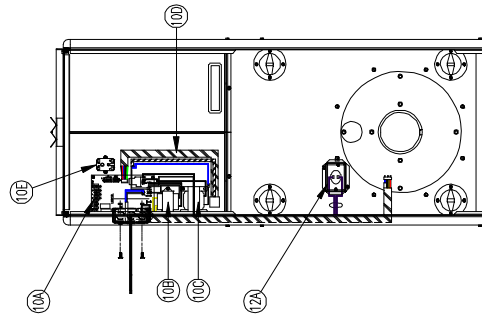

ITEM	PARTS DESCRIPTION	MODEL NO.		OD6RA072D48		OD6RA072DV5	
		PART NO.	QTY.	PART NO.	QTY.		
1	BASE	18648	1	18648	1		
2	CASING, LEFT SIDE	628645	1	628645	1		
3	CASING, RIGHT SIDE	628646	1	628646	1		
4	PANEL, FRONT SEPARATOR	618640	1	618640	1		
5	PANEL, TOP FRONT	628641	1	628641	1		
6	FRONT TOP PANEL	618714	1	618714	1		
7	HEAT EXCHANGER	38633	1	38633	1		
	HEAT EXCHANGER, GASKET KIT	AOPS7704	1	AOPS7704	1		
8	CASING, BACK	618643	1	618643	1		
9	BLOWER PAN	18677	1	18677	1		
10	CONTROL PANEL, SUB-ASSEMBLY	S00S4475	1	S00S4476	1		
11	CONTROL, FAN TIMER	50089	1	50089	1		
12	TRANSFORMER 24v	350405	1	350405	1		
13	HARNESS, VESTIBULE	350329	1	350326	1		
14	PANEL, BLOWER ACCESS (RIGHT)	19227	1	19227	1		
15	BRACKET, LIMIT SPACER	18652	1	18652	1		
16	LIMIT SWITCH	350783	1	350783	1		
17	GASKET	330119	1	330119	1		
18	FILTER RACK	628651	1	628651	1		
19	PLENUM STRIP, 18.750	618462	2	618462	2		
20	PLENUM ANGLE, 19.75"	18653	2	18653	2		
21	PLENUM ANGLE, 17.75"	18309	2	18309	2		
22	BLOWER SUB-ASSEMBLY	S00S4163	1	S00S4164	1		
23	BLOWER HOUSING, 120-9T w/WHEEL	340042	1	340042	1		
24	BLOWER WHEEL	340108	1	340108	1		
25	MOTOR MTG BRACKET ASS'Y	AOPS7670	1	AOPS7670	1		
26	MOTOR REPLACEMENT KIT	AOPS7652	1	AOPS7474	1		
27	ECM MOTOR ONLY	-	-	350256	1		
28	16x4 BOX PROGRAMMED	-	-	AOPS7506	1		
29	HARNESS, 16x4 BOX	-	-	350259	1		
30	AUXILIARY LIMIT SWITCH	350891	2	350891	2		
31	CAPACITOR 10 MFD / 370 V	350073	1	-	-		
32	HARNESS, BLOWER COMPARTMENT	350330	1	350327	1		
33	CLEAN-OUT PLUG ASSEMBLY	S00S4489	4	S00S4489	4		
	HIGH TEMP HOSE	19178	4	19178	4		
34	TRIM PLATE, CLEAN-OUT	18553	4	18553	4		
35	GASKET, TRIM PLATE	330215	4	330215	4		
36	DOOR PULL	320157	3	320157	3		
37	DRAW COLLAR	14121	1	14121	1		
38	GASKET, FLUE COLLAR	330073	1	330073	1		
39	COMBUSTION CHAMBER	AOPS7492	1	AOPS7492	1		
40	CHAMBER EXTENSION	380723	1	380723	1		
41	CHAMBER RETAINER	18557	1	18557	1		
42	PLATE, BURNER MOUNTING ASS'Y	AOPS7597	1	AOPS7597	1		
43	GASKET, BURNER MOUNTING PLATE	330212	1	330212	1		
44	COVER, OVER-FIRE DRAFT OPENING	18556	1	18556	1		
45	GASKET, OFDO COVER	330343	1	330343	1		
46	DRAFT CONTROL	370110	1	370110	1		
47	FILTER, 13"x19"x1"	370041	2	370041	2		
49	FRONT CENTER PANEL	618718	1	618718	1		
50	FRONT BOTTOM PANEL	628716	1	628716	1		

OH6/OD6/OL6 AFG BECKETT BURNER, TP2501 (380692)

Replacement parts

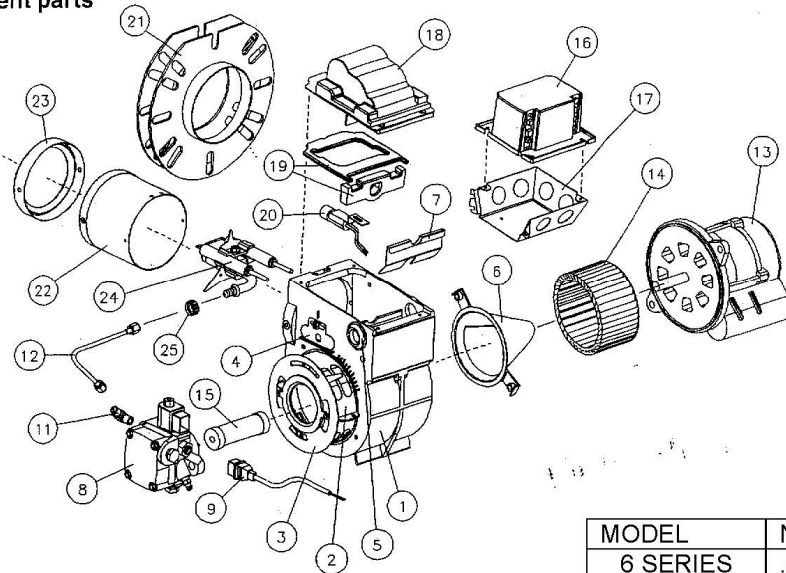

MODEL	NOZZLE SIZE	PART #
6 SERIES	.50 x 70° A	380749
	.60 X 70° B ¹	380869
	.75 X 70° B	380870

ITEM	DESCRIPTION	BECKETT PART #	TP PART #
1	BURNER HOUSING ASSY.	5874GY	
2	AIR BAND ASSY. 8 SLOT SET @ 0	5151502	
3	AIR SHUTTER, 4 SLOT, SET @ 7	3709U	380289
4	ESCUTCHEON PLATE	3493	
	SCREW	4292	
5	HOLE PLUG	2139	
6	AIR GUIDE	31231U	
7	LOW FIRING RATE BAFFLE	5880	
8	*PUMP 120 PSI	PF20322U	380674
	*SOLENOID	21755	380654
9	VALVE CORD SET	21807U	380653
11	PUMP ELBOW	2256	320815
12	CONNECTION TUBE	5394	380107
13	*MOTOR 1/7 HP 3450 RPM	21805E	380644
14	BLOWER WHEEL 4 1/4 X 2 7/16 TAB	2999	380271
15	*COUPLING	2454	380241
16	*PRIMARY CONTROL	7505B1500	350431
17	ELECTRICAL BOX	5770	
18	*IGNITER W/ GASKETS	51771U	380645
19	IGNITER GASKET KIT	51304	
20	*CAD CELL w/ SOCKET	7006U	350104
21	FLANGE WELDED TO TUBE	N/A	N/A
	GASKET	3616	380270
22	AIR TUBE COMBINATION W/FLG, GUN ASSY & HEAD	58020165	380108
	BLAST TUBE ONLY	AF60YHHSSS	
23	HEAD, F3 W/ SHIELD KIT	360063	380320
24	ELECTRODE NOZZLE ASSY	NL60YH	380706
	*ELECTRODES PAIR	5780	380269
	STATIC PLATE, 3 5/8 U	3912	
25	SPLINED NUT	3666	320121
	BULK HEAD FITTING	3488	320120

¹ Nozzle installed in burner.

Riello BF3 C8511325, TP Part# 380693 Parts List

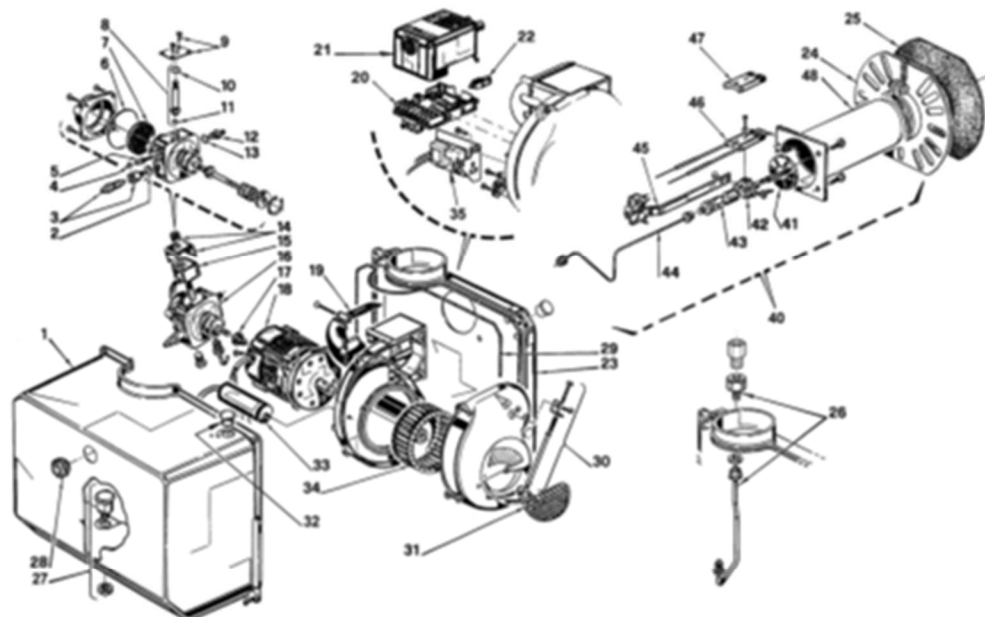

Model	Nozzle Size	Part#
6 Series	.50 X 80°A	380279
	.60 X 80°A	380398
	.70 X 80°A	380258

No.	Description	TP Part #	Riello #	No.	Description	TP Part #	Riello #
1	Burner Cover		3020270	25	Flange Gasket	380280	C688009
2	Metal Washer 3/8"		3007077	26	Supply Tube & Fitting		3008020
3	Bleeder		3007568		Two Line Kit	380705	C7001026
4	O-Ring-regulator		3007028	27	Drip		3008825
5	Regulator Screw		3007202	28	Cover Opening - Reset		3007627
6	O-Ring-cover		C7010002	29	Gasket - Burner Cover		3007630
7	Pump screen		3005719	30	Air Damper Regulator		3000681
8	Valve Stem		3006925	31	Air Damper		3008021
9	Plate - Valve Stem		3007203	32	Plug		3007706
10	O-Ring - stem upper		3007029	33	Capacitor		3005844
11	O-Ring - stem lower		3007156	34	Fan	380629	3005708
12	Nozzle Outlet Fitting		3007581	35*	AL1009 Post Purge	350383	C7001084
13	Metal Washer 5/8"		3007087	40	Combustion Head	380760	C7001376
14	Coil Bracket & Nut		3006553	41	Turbulator Disc		3006977
15	Coil	380719	3002279	42	Electrode Support		3006966
16	Pump	380633	3007802	43	Nozzle Adapter		3006965
17	Pump Drive Key		3000443	44	Nozzle Oil Tube		3008627
18	Motor	380630	3005843	45	Regulator Assembly		3008633
19	Air Tube Cover Plate		3007315	46	Electrode Assembly	380712	3008630
20	Primary Sub Base		3002278	47	Electrode Porcelain		3005869
21	Primary Control	380449	20010004	48	Air Tube w/ Flange	380710	C7001325
22	Photocell	380628	3002280	NS	Cerafelt Sleeve	380443	C6782000
23	Front Plate		3008078	NS	Gage adapter kit	380689	C7001071
24	Flange (see #48)	NA	NA				

*Optional

7/15/19

EZ1 CARLIN OIL BURNER, 380835

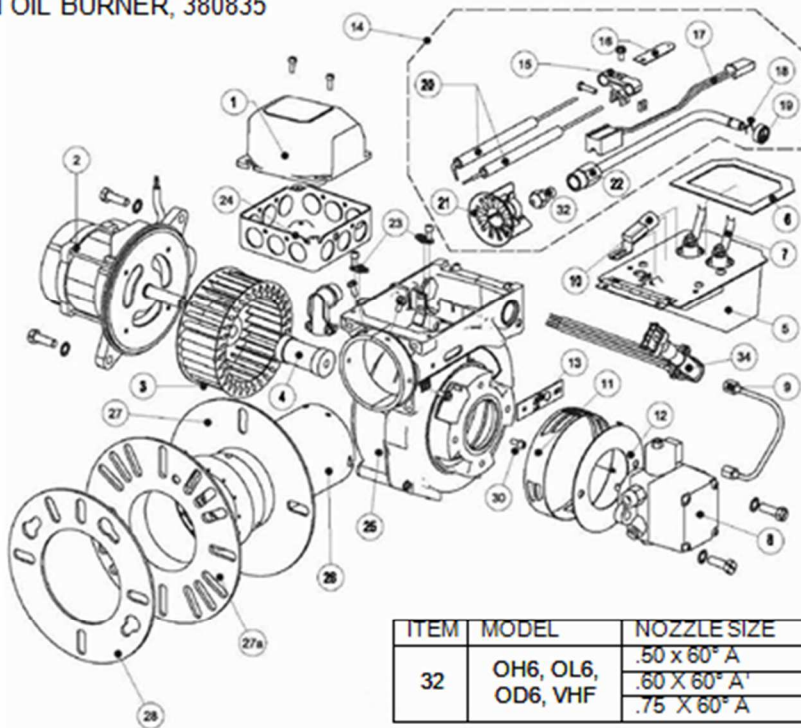

ITEM	MODEL	NOZZLE SIZE	PART #
32	OH6, OL6, OD6, VHF	.50 x 60° A	380393
		.60 X 60° A ¹	380394
		.75 X 60° A	380395

ITEM	DESCRIPTION	CARLIN PART #	TP PART #
1	PRIMARY W/ DISPLAY 70200 10S PRE / 0S POST	70200S	380845
2	1/6HP PSC MOTOR	98022S	380846
3	BLOWER WHEEL / FAN	77933S	380847
4	PUMP COUPLING	75564S	380848
5	IGNITOR	41000S	380849
6	IGNITOR BASEPLATE GASKET	40167S	
7	IGNITOR TERMINAL KIT (2 TERM. & NUTS)	24463	
8	PUMP W/SOLENOID 120 PSI	98750S	380850
	SOLENOID		380851
	PUMP ELBOW 3/16 FLARE X 1/8 NPT	29926	
9	CONNECTION TUBE	34470	380852
10	CAD CELL KIT	14407SES	380053
11 & 12	AIR BAND/AIR SHUTTER KIT @ .5	98055S	
13 & 30	HEADER BAR KIT (7 BARS & SCREW)	98055S	
14	COMBUSTION HEAD ASSY 5"	77958S	380854
15	ELECTRODE BRACKET	23135	
18 & 19	C RING & THUMB NUT KIT	50624S	
20	ELECTRODE WIRE SET	82768S	380855
21	RETENTION RING ASSY	77438S	380856
22	NOZZLE LINE ADAPTER ASSEMBLY	56820	
23	IGNITOR HOLD-DOWN TABS (2 Req.)	44842	
24	ELECTRICAL BOX	44586	
25	HOUSING	50685A	
26	AIR TUBE W/FLANGE	51242	380857
27	FLANGE	N/A	
28	FLANGE GASKET	40212	380858

¹ Nozzle installed in burner.

8/28/20



Thermo Products, LLC. "PEACE OF MIND" Warranty (Limited) Thermo Pride Oil Furnaces



Thermo Products, LLC., a Delaware corporation, hereby warrants the Thermo Pride oil fired warm air furnaces manufactured by it to be free from defects in material and workmanship under normal use and maintenance. This warranty is to the original purchaser and subsequent owners.

1ST-5TH YEAR: During the first 60 months after installation, all parts of the furnace are warranted to the current owner with the exception of maintenance items which require periodic replacement (i.e. filters, nozzles, electrodes, etc.). The owner may arrange with the original installing contractor or any other qualified contractor of the owner's choice to replace a defective part. Any labor costs involved in furnace diagnosis, service or the removal and replacement of a defective part are the responsibility of the owner.

5TH-10TH YEAR: An additional 60 months of parts coverage is extended to the verified original homeowner only. For all other owners, parts coverage terminates on the 5 year anniversary of the original installation date.

HEAT EXCHANGER WARRANTY: The heat exchanger carries a Limited Lifetime Warranty to all owners. If at any time during the warranty period the heat exchanger becomes defective, Thermo Products, LLC. will provide at its option either a replacement heat exchanger or the necessary repair parts on a no charge basis. Any labor costs involved in the diagnosis, repair or the removal and replacement of a heat exchanger are the responsibility of the owner. The owner may arrange with any qualified HVAC contractor for the necessary labor. Any transportation costs associated with the replacement of the complete heat exchanger or the repair parts are the responsibility of the owner. If Thermo Products, LLC. requests the return of the defective heat exchanger, it must be returned by prepaid transportation at the expense of the owner.

THE CONDITIONS OF THIS WARRANTY ARE:

- A. **The owner must submit the warranty registration within ninety (90) days of installation to activate the extended warranty coverage. If the original installation date cannot be verified, then the warranty period begins ninety days from the manufacture date as indicated by the model and serial number.**
- B. Defective parts (or unit when applicable) must be returned to a distributor or manufacturer through a servicing contractor for credit.
- C. The furnace must be operated within its rated capacity as indicated on the rating label and fired with the fuel for which it was designed.
- D. The furnace must operate with a duct system designed in accordance with ACCA (Air Conditioning Contractors of America) Manual D (current edition) recommendations and a vent system designed in accordance with current industry venting code(s).
- E. The furnace must be installed, set up and maintained by a qualified technician in accordance with local and state codes and/or Thermo Products, LLC. installation and operation instructions.
- F. The furnace must have been provided reasonable and necessary maintenance.
- G. The furnace must not be installed in any structure with a corrosive atmosphere or have contact with corrosive materials such as but not limited to salt, chlorine, fluorine, sulfur, recycled waste water, urine, fertilizers, rust, or other damaging substances or chemicals.
- H. Failure caused by any third party product, service, or system connected or used in conjunction with the furnace may void warranty.
- I. Limit controls which are supplied with the furnace and having pre-set maximums must not be modified, altered, or by-passed.
- J. The furnace must not be modified and/or operated in any manner other than its design configuration.
- K. No air conditioning or heat pump coil may be installed on the return air side of the furnace.
- L. The furnace must remain at its original installation address.
- M. Thermo Products, LLC. shall not be responsible for any failure due to any acts of God including but not limited to fire, water, storms, lightning, power surges, earthquakes, theft or riots.
- N. This warranty does not apply to any unit sold over the internet or by other electronic means unless the installing contractor is the purchaser of such products.

FAILURE TO COMPLY WITH ANY OF ABOVE CONDITIONS WILL VOID ANY AND ALL WARRANTIES LISTED ABOVE. THIS WARRANTY EXPRESSLY SUPERSEDES ALL OTHER WARRANTIES AND OBLIGATIONS OF THERMO PRODUCTS, LLC. NO PERSON HAS AUTHORITY TO ALTER OR MODIFY THE TERMS OF THIS WARRANTY IN ANY MANNER. THERMO PRODUCTS, LLC. ASSUMES NO LIABILITY FOR CONSEQUENTIAL DAMAGE OF ANY KIND, AND THE PURCHASER BY ACCEPTANCE OF THIS EQUIPMENT ASSUMES ALL LIABILITY FOR THE CONSEQUENCE OF ITS USE OR MISUSE BY THE PURCHASER, HIS EMPLOYEE, OR OTHERS.

Contractor Name _____ Phone _____

Address _____ Date of Installation _____

City, State, Zip _____ Installation Address _____

Model No. _____ Serial No. _____ City, State, Zip _____

Owner(s) _____ Phone _____

Register online at www.thermopride.com, top of the home page Product Warranty Registration or complete this form and mail a copy (retain a copy for your records) to: Thermo Products, LLC, PO Box 237, Denton, NC 27239 PH. 800-348-5130